

# SALO

134264/727-24-1028

134287/727-24-1033

134261/727-24-1038

134337/727-24-1039

134259/727-24-1040

134258/727-24-1041

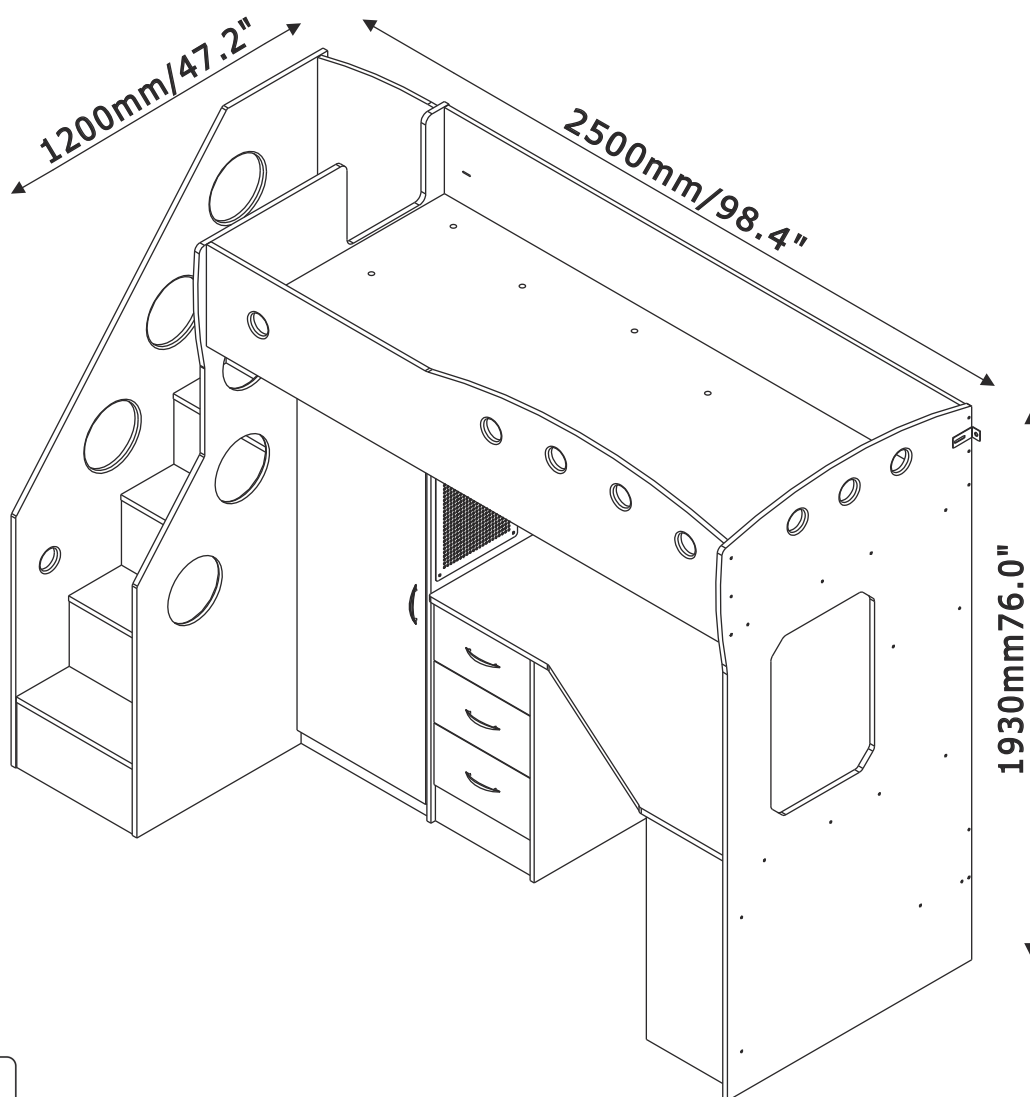

FR  
Donnez ou recyclez  
vos meubles.



Association



Magasin



Déchèterie

<https://quefairedemesdechets.fr>



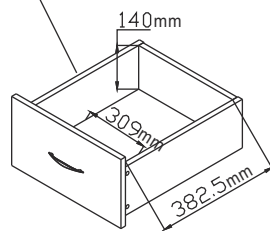
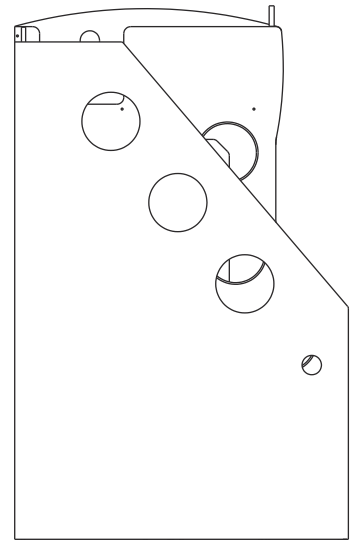
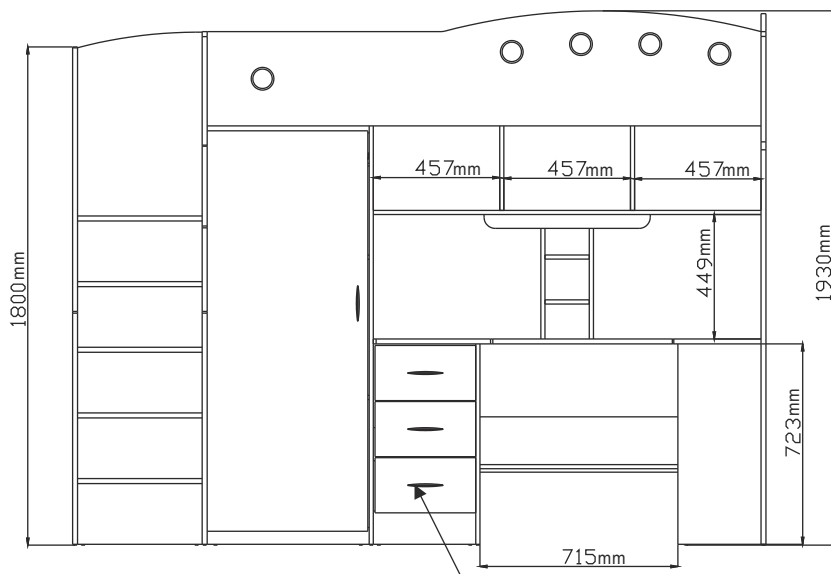
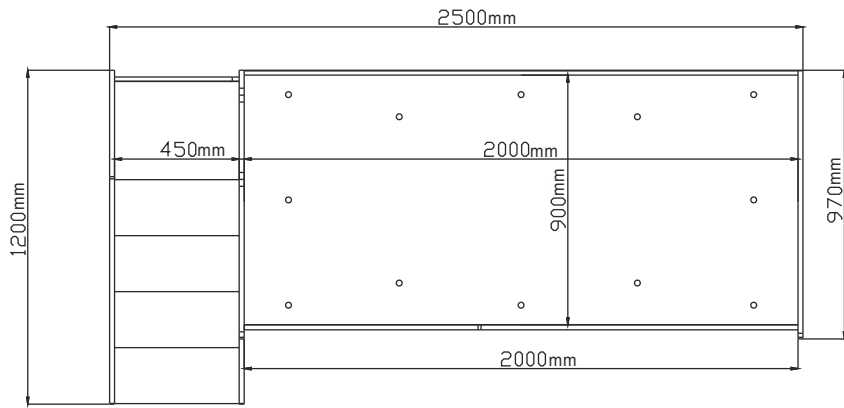

**X3**

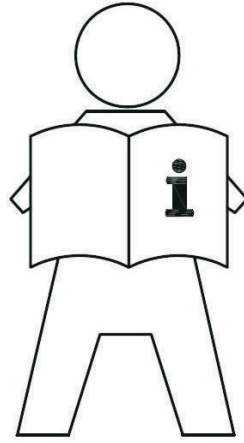

**EN: IMPORTANT INFORMATION!**

*Please read the entire manual carefully before starting to assemble and/or using this product. Follow the manual thoroughly and keep it for further reference.*

**FR: INFORMATIONS IMPORTANTES**

*Veillez lire attentivement l'ensemble du manuel avant de commencer à monter et/ou utiliser ce produit. Suivez rigoureusement le manuel et conservez-le pour toute consultation ultérieure.*

**LV: SVARĪGA INFORMĀCIJA!**

*Pirms šī izstrādājuma montāžas un/vai lietošanas uzsākšanas pilnībā izlasiet lietošanas pamācību. Stingri ievērojiet pamācības norādījumus un saglabājiet to turpmākai lietošanai.*

**LT: SVARBI INFORMACIJA!**

*Prieš pradėdami montuoti gaminį ir (arba) juo naudotis, prašome atidžiai perskaityti visą vadovą. Atidžiai skaitykite vadovą ir turėkite jį su savimi, kad galėtumėte toliau vadovautis jo nuorodomis.*

**EE: OLULINE TEAVE!**

*Enne kui alustate toote kokku panemist ja/või kasutamist, lugege see kasutusjuhend hoolikalt läbi. Järgige täpselt juhendis toodud juhiseid ja hoidke juhend alles.*

**RU: ВАЖНАЯ ИНФОРМАЦИЯ!**

*Внимательно и полностью прочитайте это руководство, прежде чем приступать к сборке или использованию этого изделия. Следуйте всем инструкциям этого руководства и сохраните его на будущее для справки.*

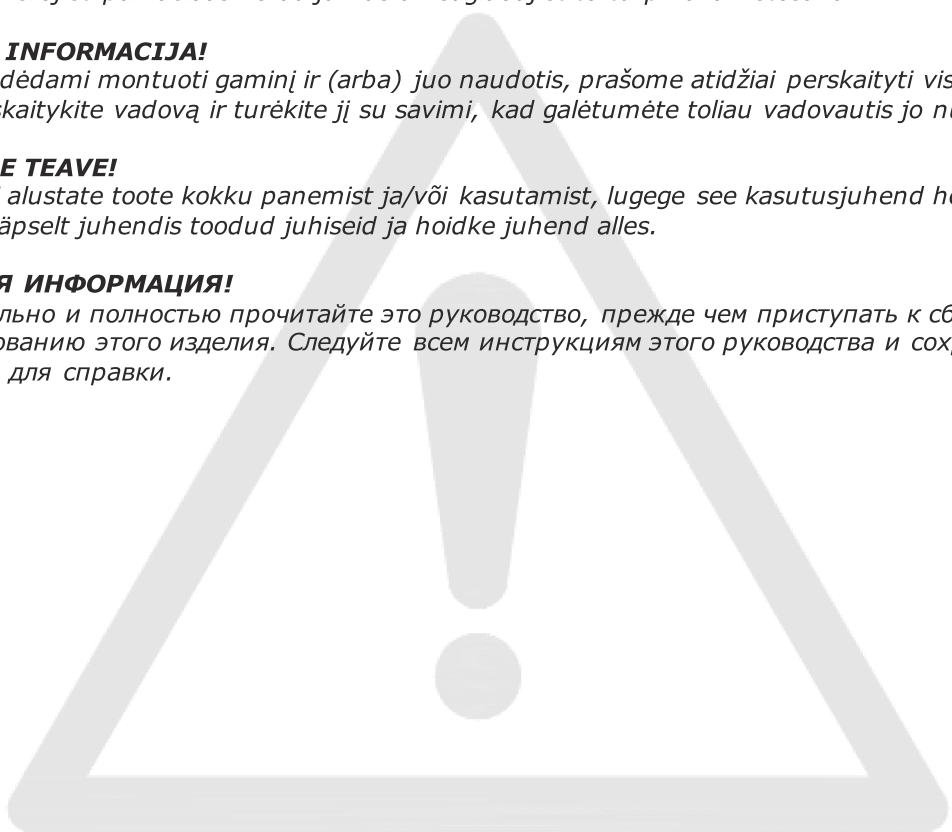

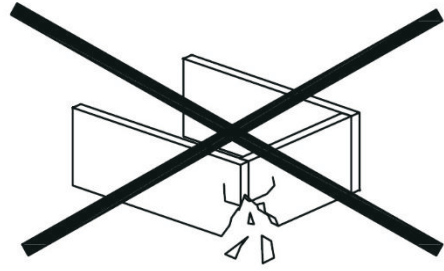
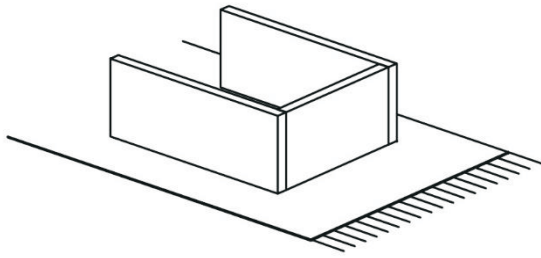

**EN: WARNING TO AVOID SCRATCHES!**

*In order to avoid scratching this furniture should be assembled on a soft layer - could be a rug.*

**FR: AVERTISSEMENT POUR ÉVITER LES RAYURES**

*Afin d'éviter les rayures, ce meuble doit être monté sur une surface souple (un tapis, par exemple).*

**LV: BRĪDINĀJUMS PAR SKRĀPĒJUMIEM!**

*Lai nesaskrāpētu šo izstrādājumu, veiciet montāžu uz mīkstas pamatnes, piemēram, paklāja.*

**LT: ĮSPĖJIMAS, KAD IŠVENGTUMĖTE ĮBRĖŽIMŲ!**

*Šio baldo nesubraižysite, jei jį surinksite ant švelnaus paviršiaus, pavyzdžiui, kilimo.*

**EE: HOIATUS KRIIMUSTUSTE VÄLTIMISEKS!**

*Kriimustuste tekkimise vältimiseks mööblile tuleb see kokku panna pehmel pinnal, nt kaltsuvaibal.*

**RU: ПРЕДУПРЕЖДЕНИЕ ОТНОСИТЕЛЬНО ЦАРАПИН!**

*Во избежание нанесения царапин, сборку этой мебели необходимо выполнять на мягкой поверхности, например на ковре.*

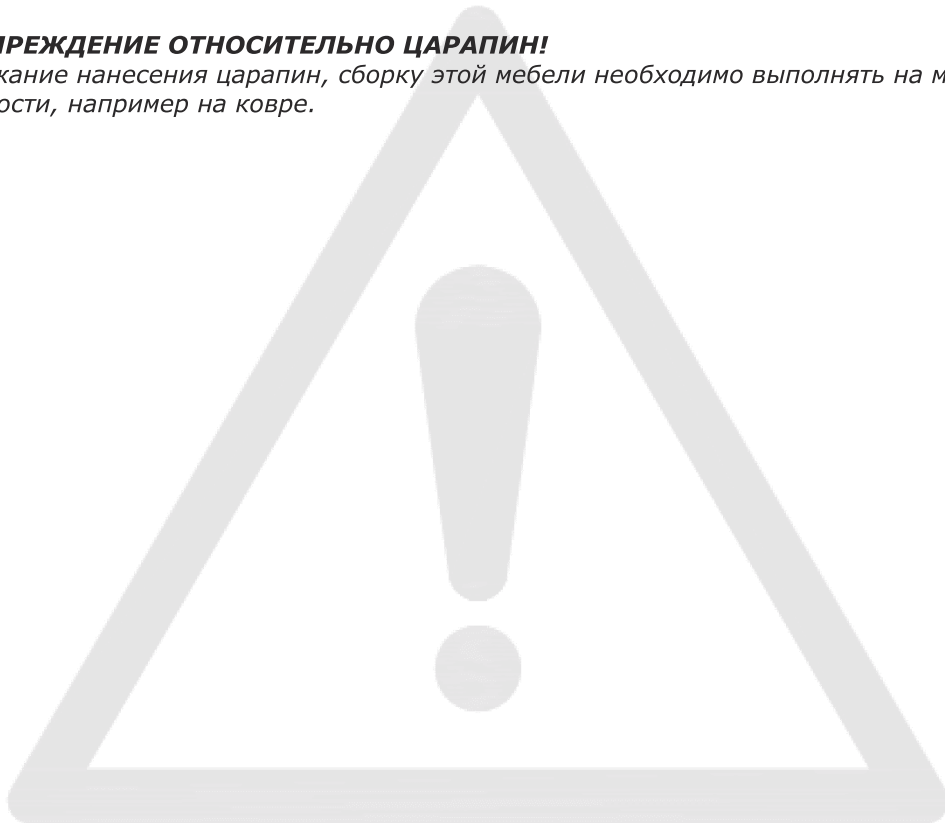

**EN: IMPORTANT!**

*It is important that any product which is assembled using any kind of screw is re-tightened 2 weeks after assembly, and once every 3 months - in order to assure stability through-out the lifespan of the product.*

**FR: IMPORTANT**

*Il est important que tout produit monté à l'aide de vis soit resserré 2 semaines après son montage, puis tous les 3 mois, afin de garantir sa stabilité durant tout son cycle de vie.*

**LV: SVARĪGI!**

*Ir svarīgi, lai jebkuram produktam, kas tiek uzstādīts ar jebkādu skrūvju palīdzību, skrūves tiktu atkārtoti pievilktas 2 nedēļas pēc montāžas, pēc tam – reizi 3 mēnešos, tā nodrošinot stabilitāti visā izstrādājuma kalpošanas laikā.*

**LT: SVARBU!**

*Bet kokį varžtais tvirtinamą gaminį 2 savaites po surinkimo bei kas 3 mėnesius reikia papildomai suveržti – taip užtikrinamas naudojamo gaminio stabilumas.*

**EE: TÄHTIS!**

*Oluline on, et toote kruvisid pingutataks 2 nädalat pärast kokkupanekut ja seejärel iga 3 kuu järel, et tagada stabiilsus kogu toote eluea jooksul.*

**RU: ВАЖНО!**

*В любом изделии, собранном с использованием винтов любого типа, необходимо через 2 недели после сборки и в дальнейшем каждые 3 месяца подтягивать винты, чтобы обеспечить прочность изделия в течение срока эксплуатации.*





**EN: GENERAL INSTRUCTION FOR FURNITURE SURFACES!**

*Wipe clean with a damp cloth. Use only water or a gentle detergent.  
Wipe dry with a clean cloth.*

**FR: INSTRUCTIONS GÉNÉRALES POUR LE MOBILIER**

*Nettoyer à l'aide d'un chiffon humide. Utiliser uniquement de l'eau ou un détergent doux.  
Essuyer à l'aide d'un chiffon propre.*

**LV: VISPĀRĪGI KOPŠANAS NORĀDĪJUMI MĒBEĻU VIRSMĀM!**

*Noslaukiet ar mitru drānu. Lietojiet tikai ūdeni vai maigu mazgāšanas līdzekli.  
Nosusiniet ar tīru drānu.*

**LT: BENDRIEJI NURODYMAI DĖL BALDŲ PAVIRŠIŲ!**

*Valykite drėgnu skudurėliu. Naudokite tik vandenį arba švelnų valiklį.  
Nusausinkite švari skudurėliu.*

**EE: ÜLDISED JUHISED MÖÖBLIPINDADE JAOKS!**

*Kasutage puhastamiseks niisket lappi. Kasutage ainult vett või õrnatoimelist puhastusvahendit.  
Pühkige puhta lapiga kuivaks.*

**RU: ОБЩИЕ ПРАВИЛА ЭКСПЛУАТАЦИИ МЕБЕЛЬНЫХ ПОВЕРХНОСТЕЙ!**

*Очистите изделие чистой влажной тканью. Используйте мягкодействующее моющее средство.  
Вытрите досуха чистой тряпкой.*

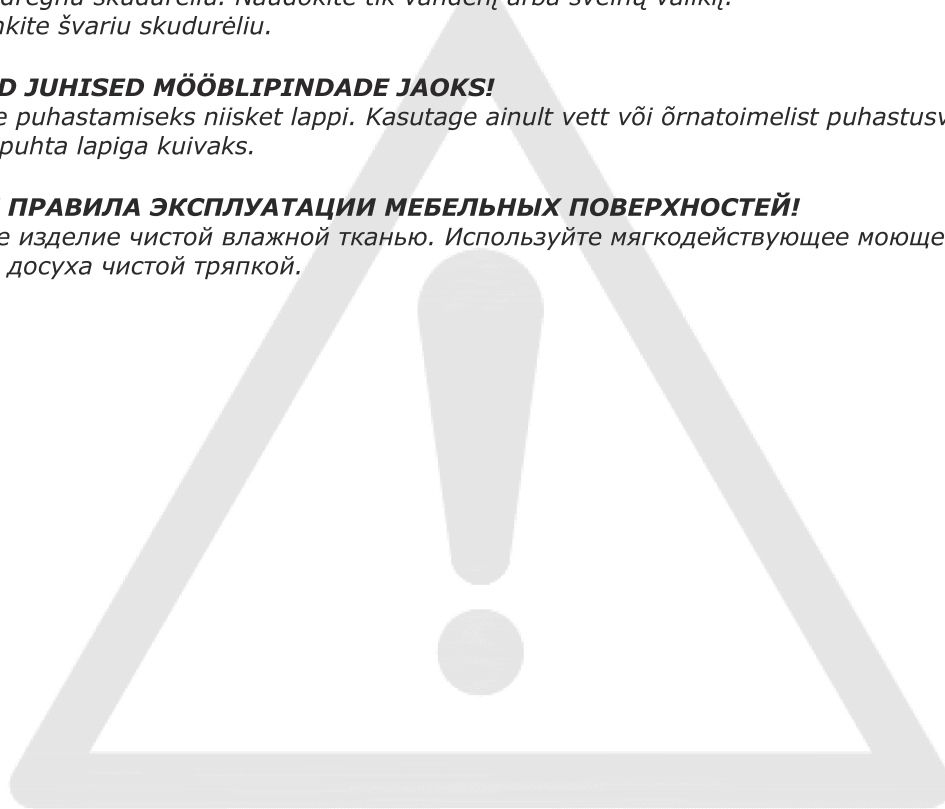

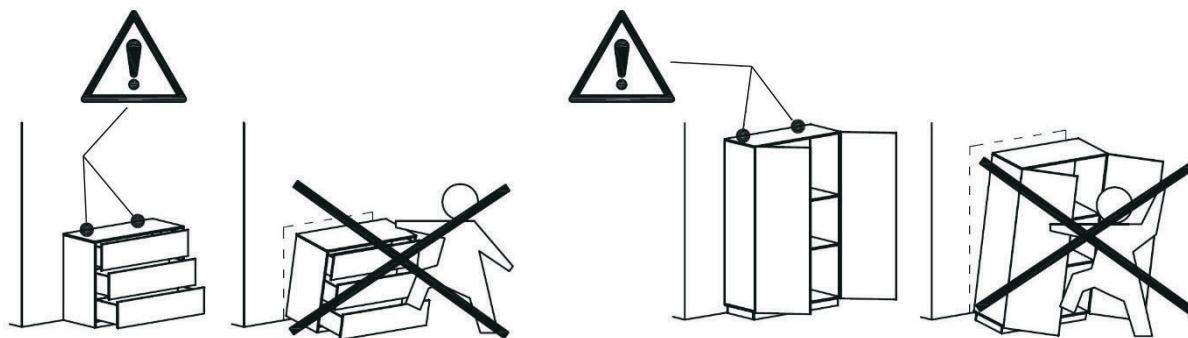

**EN: ANTI-TOPPLE WARNING!**

*This product has to be permanently fixed to the wall with the bracket(s) included, to avoid fatal injury in case it topples over. The pack only contains screws for fastening the anti-topple bracket(s) itself to the product. Please contact your DIY or hardware store for advice on the correct type of screws/raw plugs for your type of wall.*

**FR: AVERTISSEMENT ANTIBASCULEMENT**

*Ce produit doit être fixé de manière permanente au mur à l'aide du/des support(s) inclus afin d'éviter des blessures mortelles en cas de basculement. L'emballage contient des vis pour attacher le(s) support(s) antibasculement au produit. Veuillez contacter votre magasin de bricolage ou votre quincaillerie pour obtenir des conseils sur le type de vis/chevilles adapté à votre mur.*

**LV: BRĪDINĀJUMS PAR APGĀŠANOS!**

*Šis produkts ir jāpiestiprina pie sienas ar komplektā iekļauto(-ajiem) kronšteinu(-iem), lai novērstu nāvējošu savainojumu risku, tam apgāžoties. Iepakojumā ir skrūves tikai pretapgāšanās kronšteina(-u) piestiprināšanai pie produkta. Informāciju par to, kādas skrūves piemērotas Jūsu sienai, jautājiet saimniecības preču vai būvizstrādājumu veikalā.*

**LT: ĮSPĖJIMAS DĖL NUVERTIMO!**

*Šį gaminį būtina tinkamai pritvirtinti prie sienos naudojant pridėtas gembes, kad išvengtumėte mirtino sužalojimo jam nuvirtus. Pakuotėje yra tik varžtai gembėms prie gaminio pritvirtinti. Užėikite į artimiausią statybinių prekių parduotuvę ir paprašykite savo sienai tinkamiausių varžtų (kaiščių).*

**EE: ÜMBERKUKKUMISOHT!**

*Toote ümberkukkumisest tuleneda võiva eluohtliku õnnetuse vältimiseks tuleb see kinnitada komplekti kuuluva(te) kronsteini(de) abil püsivalt seina külge. Komplekti kuuluvad ainult kruvid, mis on mõeldud ümberkukkumist takistava(te) kronsteini(de) kinnitamiseks toote külge. Soovituste saamiseks sobivate kruvide/tüüblite leidmiseks oma seina jaoks, konsulteerige DIY esindaja või rauakaupade kaupluse müüjaga.*

**RU: ПРЕДУПРЕЖДЕНИЕ ОБ ОПРОКИДЫВАНИИ!**

*Во избежание опрокидывания это изделие должно быть надежно прикреплено к стене с помощью прилагаемых кронштейнов. В комплект входят винты только для прикрепления кронштейнов к самому изделию. Шурупы и дюбели для крепления к стене конкретного типа можно найти в строительном или хозяйственном магазине.*

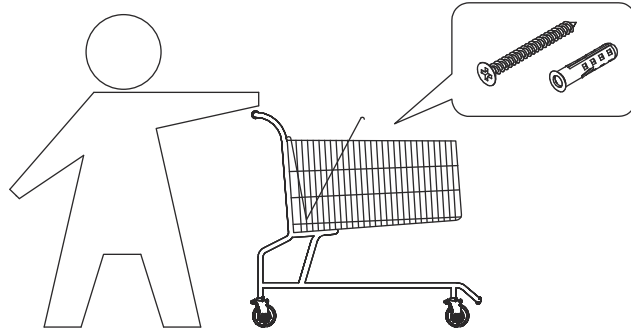

**EN: IMPORTANT!**

Mounting screws are not included.

Always make sure that the fastening method you choose is suitable and safe for your home.

**FR: IMPORTANT!**

Les vis de montage ne sont pas fournies.

Assurez-vous toujours que la méthode de montage que vous choisissez convienne à votre domicile et soit sûre.

**LV: SVARĪGI!**

Montāžas skrūves nav iekļautas komplektācijā.

Vienmēr pārlicinieties, ka jūsu izvēlēta stiprināšanas metode ir piemērota un droša jūsu mājoklim.

**LT: SVARBU!**

Tvirtinimo varžtai prie gaminio nėra pridėti.

Pagalvokite, ar pasirinktas tvirtinimo būdas yra tinkamas Jūsų namams ir yra saugus.

**EE: TÄHTIS!**

Kinnituskruvid ei kuulu komplekti.

Alati veenduge, et teie valitud kinnitusmeetod on teie kodu jaoks sobiv ja ohutu.

**RU: ВАЖНО!**

Крепежные шурупы не входят в комплект.

Обязательно убедитесь, что выбранный способ крепления является допустимым и безопасным для вашего дома.

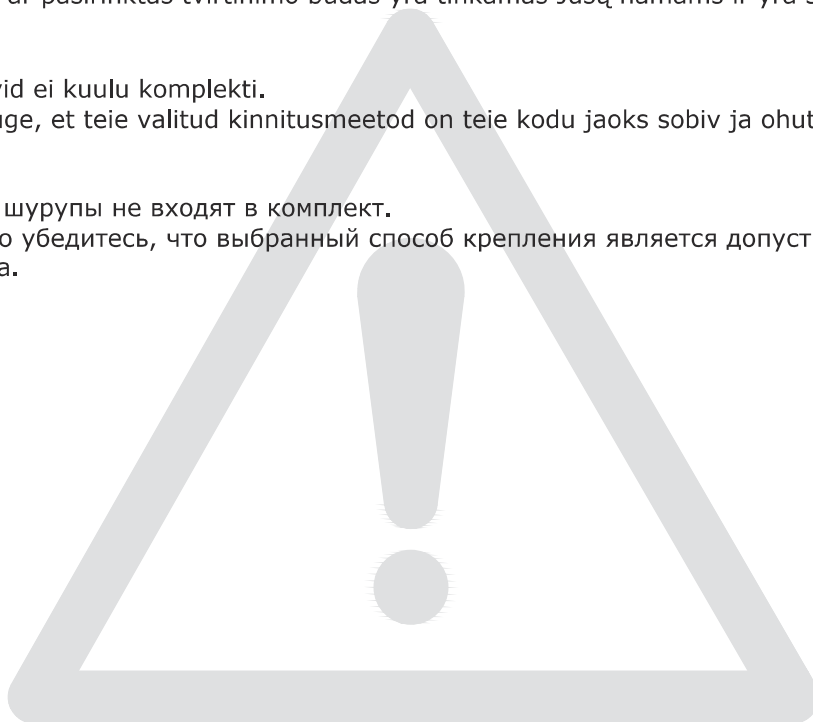

**EN: IMPORTANT – READ CAREFULLY – RETAIN FOR FUTURE REFERENCE**

This bed has been tested and is compliance with European Standards EN 747-1:2024; EN 747-2:2024.

Always follow the manufacturer's instructions on assembly and use.



- WARNING** - This bed is not suitable for children under six years due to the risk of injury from falls.
- WARNING** - Bunk beds and high beds can present a serious risk of injury from strangulation if not used correctly. Never attach or hang items to any part of the bunk bed that are not designed to be used with the bed, for example, but not limited to ropes, strings, cords, hooks, belts and bags.
- WARNING** - Children can become trapped between the bed and the wall, a roof pitch, the ceiling, adjoining pieces of furniture (e.g. cupboards) and the like. To avoid risk of serious injury the distance between the top safety barrier and the adjoining structure shall not exceed 75 mm or shall be more than 230 mm.
- WARNING** - Do not use the bunk bed/high bed if any structural part is broken or missing.
- WARNING** - Always ensure the platform and the ladder/ stairs are permanently attached to this bunk bed before use.
- WARNING** - This product must be attached to the wall or building structure.

- The recommended size of the mattress to be used with the bed is 900 mm x 2000 mm.
- Maximum mattress thickness: 110 mm. Max thickness of the mattress to be used with the upper bed must be at least 7.01" (178 mm) below the upper edge of the safety barrier. Maximum thickness of the mattress to be used with the bed is shown on the bed detail with number 22.
- Ventilation of the room is necessary in order to keep the humidity low and to prevent mould in and around the bed.
- Always use the ladder for entering and leaving the upper bed.
- Check regularly that all assembly fastenings are properly tightened. Retighten the fastenings as necessary.
- Importer and distributor: SIA "Do It", Bikeru street 4, Ulbroka, Stopinu parish, Ropazu municipality, LV-1079, Latvia; info@doit.lv

**FR: IMPORTANT – LIRE ATTENTIVEMENT - CONSERVER POUR RÉFÉRENCE ULTÉRIEURE**

Ce lit a été testé et est en conformité avec la norme européenne pour les lits EN 747-1:2024; EN 747-2:2024.

Suivez toujours les instructions du fabricant pour l'assemblage et l'utilisation.



- AVERTISSEMENT** - Ce lit ne convient pas aux enfants de moins de six ans en raison du risque de blessures dues aux chutes.
- AVERTISSEMENT** - Les lits superposés et les lits surélevés peuvent présenter un risque sérieux de blessure par strangulation s'ils ne sont pas utilisés correctement. Ne jamais attacher ou suspendre des éléments du lit superposé qui ne sont pas conçus pour être utilisés avec le lit, par exemple, mais ne se limitant pas à des cordes, des ficelles, des guirlandes, des crochets, des ceintures et des sacs.
- AVERTISSEMENT** - Les enfants peuvent se coincer entre le lit et le mur, la pente du plafond, le plafond, des meubles adjacents (par exemple, des armoires), etc. Pour éviter tout risque de blessure grave, la distance entre la barrière de sécurité supérieure et la structure adjacente ne doit pas dépasser 75 mm ni dépasser 230 mm.
- AVERTISSEMENT** - N'utilisez pas le lit superposé / le lit surélevé si une partie de la structure est cassée ou manquante.
- AVERTISSEMENT** - Assurez-vous que la plate-forme et l'escalier soient fixés de manière permanente au lit superposé avant de l'utiliser.
- AVERTISSEMENT** - Ce produit doit être fixé au mur ou à la structure du bâtiment.

- La taille recommandée du matelas à utiliser avec le lit est de 900 mm x 2000 mm.
- Épaisseur maximale du matelas: 110 mm. L'épaisseur maximale du matelas à utiliser avec le lit supérieur doit se trouver au moins 7,01 (178 mm) sous le bord supérieur de la barrière de sécurité. L'épaisseur maximale du matelas à utiliser avec le lit est indiquée sur le détail du lit avec le numéro 22.
- La ventilation de la pièce est nécessaire pour maintenir un faible taux d'humidité et éviter la formation de moisissures à l'intérieur et autour du lit.
- Utilisez toujours l'échelle pour entrer et sortir du lit supérieur.

- Vérifiez régulièrement que toutes les fixations de l'assemblage soient correctement serrées. Resserrez les fixations si nécessaire.
- Importateur et distributeur: SIA "Do It", Bikeru street 4, Ulbroka, Stopinu parish, Ropazu municipality, LV-1079, Latvia; info@doit.lv

**LV: SVARĪGI – RŪPĪGI IZLASIET – SAGLABĀJIET TURPMĀKAI UZZIŅAI**

Šī gulta ir testēta un atbilst Eiropas standartiem  
EN 747-1:2024; EN 747-2:2024.



Vienmēr ievērojiet ražotāja norādījumus par montāžu un lietošanu.

**BRĪDINĀJUMS** - Šī gulta nav piemērota bērniem, kas jaunāki par sešiem gadiem, jo pastāv risks gūt traumas krītot.

**BRĪDINĀJUMS** – Vairākstāvu gultas un augstās gultas var radīt nopietnu nožņaugšanās risku, ja tās netiek lietotas pareizi. Nekādā gadījumā nepiestipriniet un nekariniet uz vairākstāvu gultas detaļām piederumus, kas nav paredzēti lietošanai ar gultu, tostarp, bet ne tikai virves, auklas, saites, āķus, siksnas un somas.

**BRĪDINĀJUMS** - Bērni var iesprūst starp gultu un sienu, jumta slīpni, griestiem, blakus esošajām mēbelēm (piemēram, skapjiem) un tamlīdzīgi. Lai novērstu nopietnu savainojumu risku, attālums starp augšējo drošības barjeru un blakus esošo konstrukciju nedrīkst būt lielāks par 75 mm vai tam jābūt lielākam par 230 mm.

**BRĪDINĀJUMS** - Nelietojiet vairākstāvu gultu/augsto gultu, ja ir bojāta vai nozaudēta kāda tās detaļa.

**BRĪDINĀJUMS** – Pirms lietošanas vienmēr pārlicinieties, ka platforma un kāpnes/trepes ir stingri piestiprinātas šai divstāvu gultai.

**BRĪDINĀJUMS** – Šim produktam jābūt piestiprinātam pie sienas vai ēkas konstrukcijas.

- Ieteicamais matrača izmērs lietošanai ar gultu: 900 mm x 2000 mm.
- Maksimālais matrača augstums: 110 mm. Gultā izmantojamā matrača maksimālajam biezumam jābūt vismaz 178 mm zem drošības barjeru augšējās malas. Gultai izmantojamā matrača maksimālais augstums ir norādīts uz gultas detaļas Nr. 22.
- Telpas vēdināšana ir nepieciešama, lai uzturētu zemu mitruma līmeni un novērstu pelējuma veidošanos gultā un ap to.
- Iekāpšanai augšējā gultā un izkāpšanai no tās obligāti jāizmanto trepes.
- Regulāri pārbaudiet, vai visi montāžas stiprinājumi ir pareizi pievilkti. Vajadzības gadījumā pievelciet stiprinājumus.
- Importētājs un izplatītājs: SIA "Do It", Bikeru iela 4, Ulbroka, Stopiņu pagasts, Ropažu novads, LV-1079, Latvija; info@doit.lv

**LT: SVARBU – ATIDŽIAI PERSKAITYKITE – PASILIKITE ATEIČIAI**

Šī lova buvo patikrinta ir atitinka europinius reikalavimus  
EN 747-1:2024; EN 747-2:2024.



Visuomet vadovaukitės gamintojo surinkimo ir naudojimo instrukcijomis.

**ĪSPĒJIMAS** - Šī lova netinka jaunesniems nei šēseriņ metų vaikams dėl pavojaus susižaloti nukritus.

**ĪSPĒJIMAS** - Aviaukštės lovos ir aukštos lovos kelia didelį pavojų pasismaugti, jei jos netinkamai naudojamos. Niekada nekabinkite ar netvirtinkite daiktų prie jokios dviaukštės lovos dalies, jei jie neskirti naudoti su lova, pavyzdžiui, bet neapsiribojant, virvių, virvelių, laidų, kabliukų, diržų ir maišelių.

**ĪSPĒJIMAS** - Vaikai gali įstrigti tarp lovos ir sienos, stogo šlaito, lubų, šalia stovinių baldų (pvz., spintelės) ir panašiai. Siekiant išvengti rimtų susižalojimų rizikos, atstumas tarp viršutinės apsauginės užtvoros ir gretutinio baldo ar konstrukcijos neturi viršyti 75 mm arba turi būti didesnis nei 230 mm.

**ĪSPĒJIMAS** - Nenaudokite dviaukštės lovos ar aukštos lovos, jei trūksta lovos dalies arba bet kuri dalis yra sulūžusi.

**ĪSPĒJIMAS** – Prieš naudodami šią dviaukštę lovą visada įsitikinkite, kad pakyla ir kopėčios / laiptai yra tvirtai pritvirtinti prie jos.

**ĪSPĒJIMAS** – Šis gaminytis turi būti pritvirtintas prie sienos arba pastato konstrukcijos.

- Rekomenduojamas čiužinio dydis yra 900 mm x 2000 mm.
- Didžiausias čiužinio storis: 110 mm. Maksimalus čiužinio storis turi būti toks, kad iki viršutinės lovos apsaugos krašto liktų bent 178 mm. Didžiausias galimas šiai lovai tinkancio čiužinio storis yra nurodytas (žr. 22 detalę).
- Būtina vėdinti patalpą, kad joje būtų mažai drėgmės ir kad lovoje ir aplink ją nesusidarytų

pelēsis.

- Ant viršutinēs lovos užlipkite ir nuo jos nulipkite kopėtėlėmis.
- Reguliariai tikrinkite, ar visi surenkamieji tvirtinimo elementai yra tinkamai priveržti. Prireikus dar kartą priveržkite tvirtinimo elementus.
- Importuotojas ir platintojas: SIA "Do It", Bikeru iela 4, Ulbroka, Stopinu pag., Ropazu nov., LV-1079, Latvija; info@doit.lv

**EE: TÄHTIS! LUGEGE HOOLIKALT LÄBI JA HOIDKE ALLES.**

Seda voodit on testitud ning see vastab voodite Euroopa standarditele  
EN 747-1:2024; EN 747-2:2024.



Kokkumonteerimisel ja kasutamisel järgige alati tootja juhiseid.

**HOIATUS** - See voodi ei sobi alla kuueaastastele lastele võimalikust kukumisest tuleneva vigastusohu tõttu.

**HOIATUS** - Narid ja kõrged voodid võivad põhjustada lämbumisohust tuleneva raske vigastuse, kuineid ei kasutata õigesti. Ärge kinnitage ega riputage narile ühtegi asja, mis ei ole mõeldud kasutamiseks koos voodiga. Muuhulgas näiteks trossid, nõörid, paelad, konksud, vööd ja kotid.

**HOIATUS** - Lapsed võivad voodi ja seina, katusekalde, lae, mööbli (nt kappide) ühenduselementide jms vahele kinni jääda. Raskete vigastustega lõppeva õnnetuse vältimiseks ei tohi ülemise kaitsepiirde ja kõrvaloleva konstruktsiooni vahele jääda üle 75 mm või selline vahe peab olema suurem kui 230 mm.

**HOIATUS** - Nari/kõrget voodit ei tohi kasutada, kui mõni selle konstruktsioonilistest elementidest on purunenud või puudub.

**HOIATUS** - Enne kasutamist veenduge, et platvorm ja redel/trepp on narivoodi külge püsivalt kinnitatud.

**HOIATUS** - See toode tuleb kinnitada seina või ehituskonstruktsiooni külge.

- Voodile sobib madrats mõõtudega 900 mm x 2000 mm.
- Madratsi maksimaalne paksus: 110 mm. Voodis kasutatava madratsi maksimaalne paksus peab jääma vähemalt 178 mm alla turvapiirde ülemise serva. Voodis kasutatava madratsi maksimumpaksus on toodud voodidetailil numbriga 22.
- Ruumi õhutamine on vajalik selleks, et hoida õhuniiskuse tase madal ning vältida hallituse tekkimist voodis ja selle ümber.
- Kasutage kõrgendustega voodisse minemiseks ja maha tulemiseks alati redelit.
- Kontrollige regulaarselt, et kõik kinnitustarvikud oleksid korralikult pingutatud. Vajadusel pingutage kinnitustarvikud uuesti.
- Importija ja müüja: SIA "Do It", Bikeru iela 4, Ulbroka, Stopinu pag., Ropazu nov., LV-1079, Läti; info@doit.lv

**RU: ВАЖНО! ВНИМАТЕЛЬНО ПРОЧИТАЙТЕ И СОХРАНИТЕ НА СЛУЧАЙ, ЕСЛИ ПОНАДОБИТСЯ ПЕРЕЧИТАТЬ**

Эта кровать проверена и соответствует европейским стандартам  
EN 747-1:2024; EN 747-2:2024.



Всегда следуйте указаниям производителя по монтажу и использованию.

**ПРЕДУПРЕЖДЕНИЕ** - Данная кровать не подходит для детей младше шести лет из-за риска получения травм при падении.

**ПРЕДУПРЕЖДЕНИЕ** - Многоэтажные и высокие кровати могут создать серьезный риск удушья при неправильном их использовании. Ни в коем случае не прикрепляйте и не вешайте на детали многоэтажных кроватей принадлежности, не предназначенные для использования вместе с кроватью, в том числе, но не только веревки, шнурки, ленты, крючки, ремни и сумки.

**ПРЕДУПРЕЖДЕНИЕ** - Дети могут застрять в пространстве между кроватью и стеной, скатом крыши, потолком, стоящей рядом мебелью (например, шкафами) и т. п. В целях предупреждения серьезного риска получения травмы расстояние между верхним барьером безопасности и расположенной рядом конструкцией не должно превышать 75 мм или должно быть больше 230 мм.

**ПРЕДУПРЕЖДЕНИЕ** - Не пользуйтесь многоярусной/высокой кроватью, если повреждена или утеряна хоть одна из ее деталей.

**ПРЕДУПРЕЖДЕНИЕ** - Перед использованием обязательно убедитесь, что платформа и лестница/ступеньки надежно прикреплены к двухъярусной кровати.

**ПРЕДУПРЕЖДЕНИЕ** - Данное изделие должно быть прикреплено к стене или конструкции здания.

- Рекомендуемый размер матраса для использования вместе с кроватью: 900 мм × 2000 мм.
- Максимальная высота матраса: 110 мм. Расстояние между верхней поверхностью матраса и верхним краем ограждения должно быть не менее 178 мм. Максимальная высота матраса, используемого для кровати, указаны на деталь кровати номер 22.
- Вентиляция помещения необходима для поддержания низкой влажности и предотвращения появления плесени внутри и вокруг кровати.
- Обязательно использовать лестницу для того, чтобы забраться на верхнюю кровать и спустите с верхней кровати.
- Регулярно проверяйте, надежно ли затянуты все крепежные элементы. При необходимости повторно затяните крепежные элементы.
- Импортёр и дистрибьютор: SIA "Do It", Bikeru iela 4, Ulbroka, Stopinu pag., Ropazu nov., LV-1079, Latvija; info@doit.lv



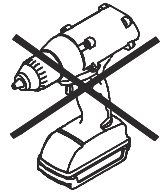
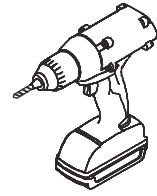
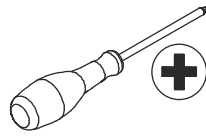
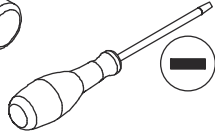
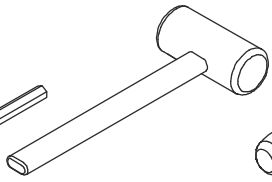
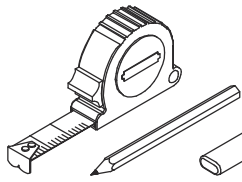

**Ax60**

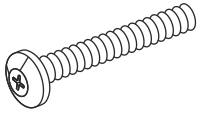

**M6X45mm**

**Bx62**



**M6X10mm**

**Cx6**

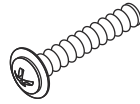

**M4X21mm**

**Dx2**

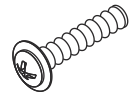

**M4X18mm**

**Ex83**

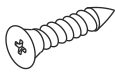

**3.5X14mm**

**Fx41**

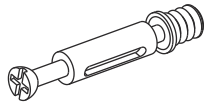

**M6X40mm**

**Gx41**



**Ø15X11.3mm**

**Hx51**

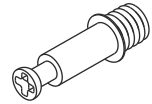

**M6X25mm**

**Jx20**

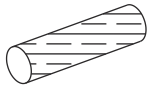

**Ø6X30mm**

**Kx4**



**Lx2**



**Mx4**

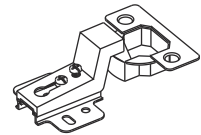

**Nx4**



**Px1**



**Ø60mm**

**Qx46**

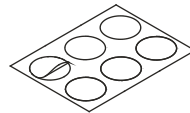

**Ø21mm**

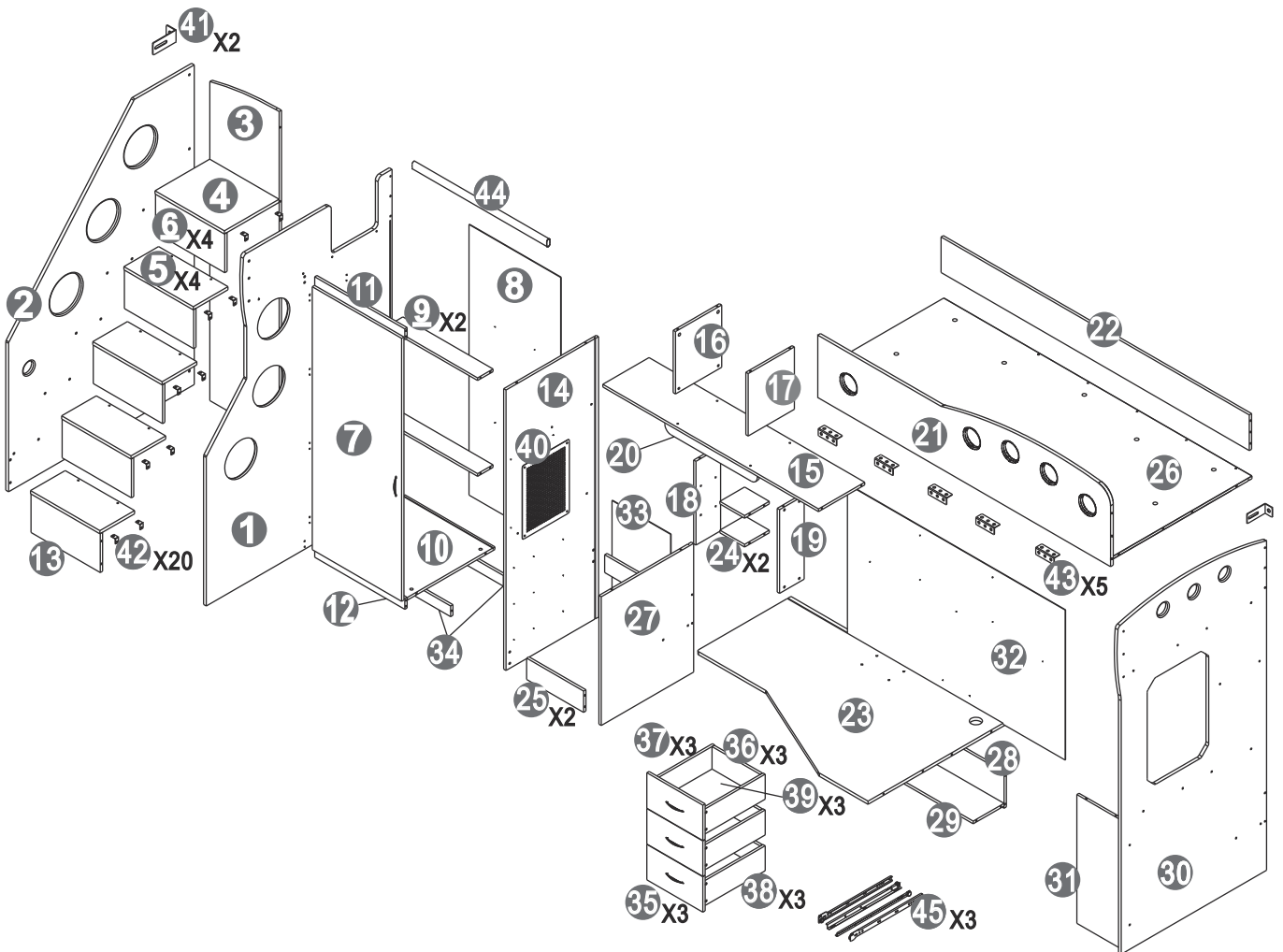

# BOX 1/5

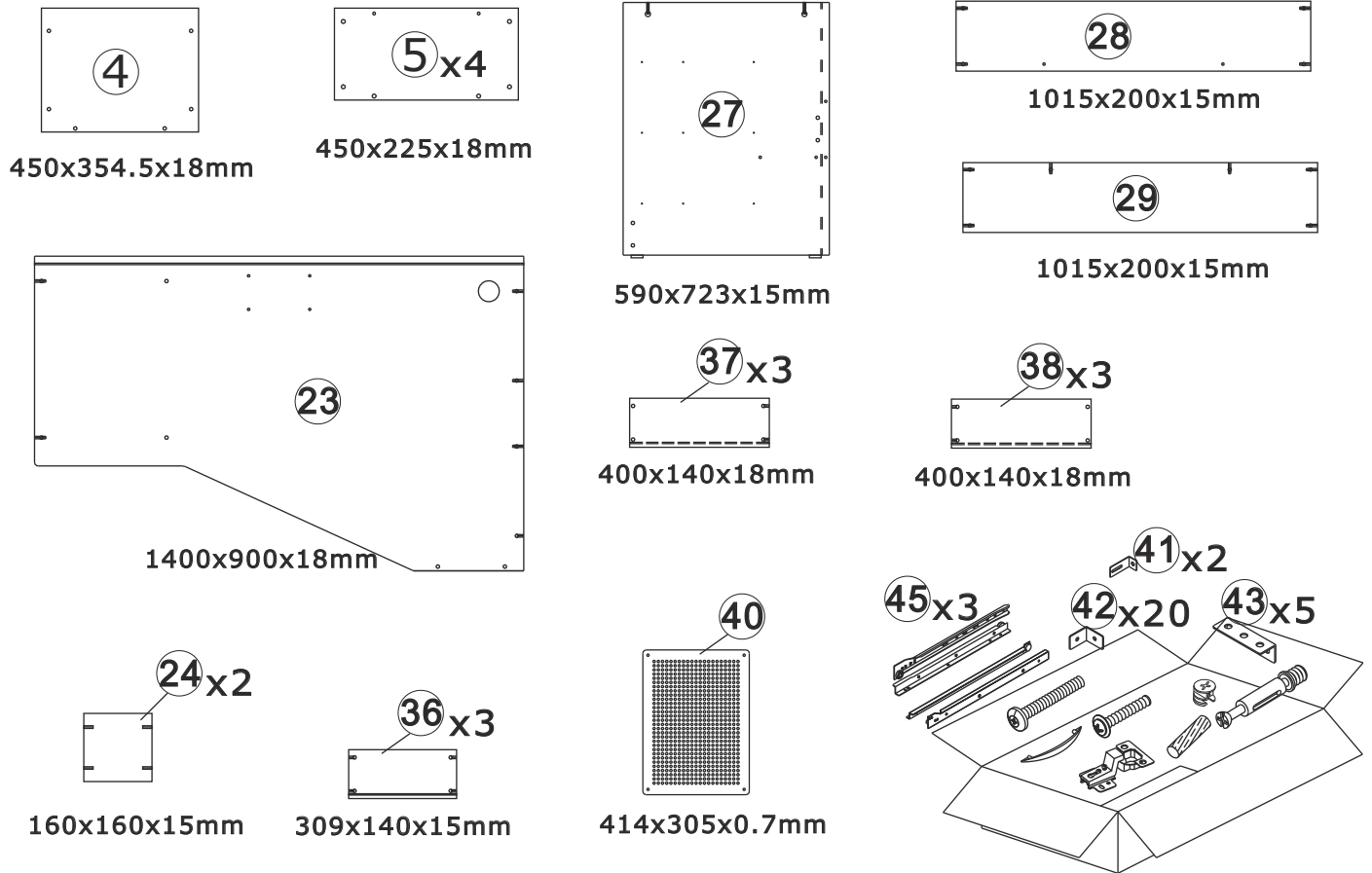

# BOX 2/5

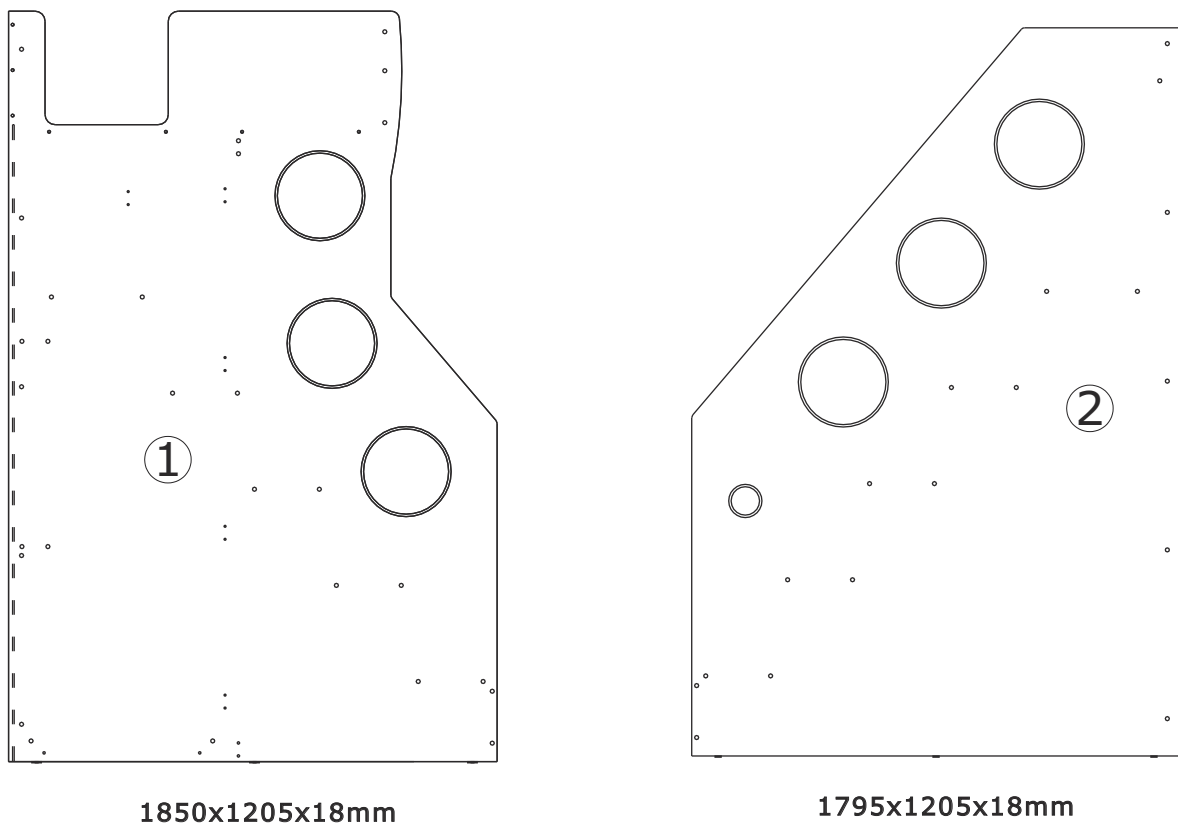

# BOX 3/5



1848x450x15mm

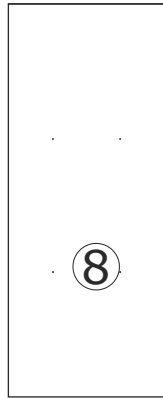

1495x595x3mm

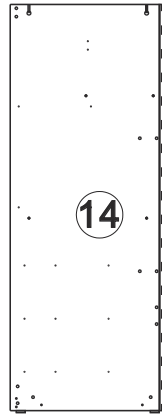

1545x590x15mm

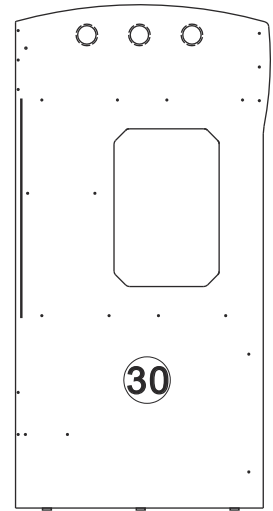

1915x970x18mm

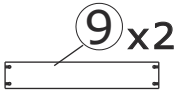

585x100x15mm

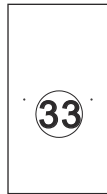

720x380x3mm



584x43x15mm

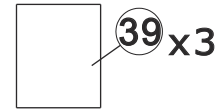

393x320x3mm

# BOX 4/5

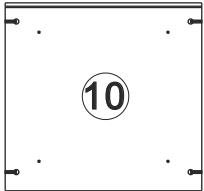

585x559x15mm

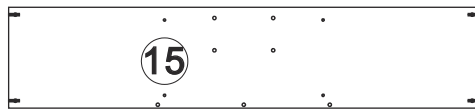

1400x300x15mm



340x300x15mm

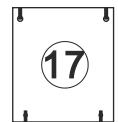

340x300x15mm

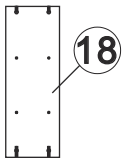

449x160x15mm

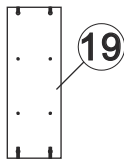

449x160x15mm



2000x288x15mm

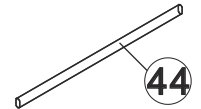

577x28.5x14mm

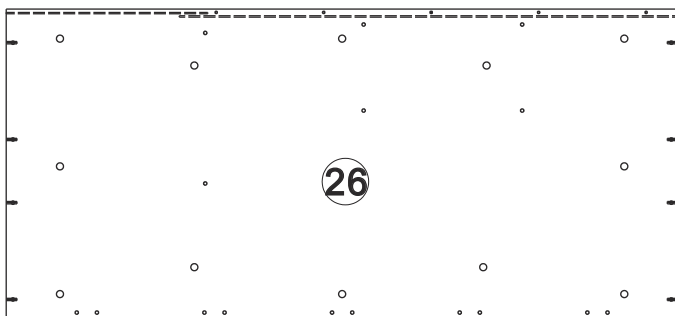

2000x918x15mm

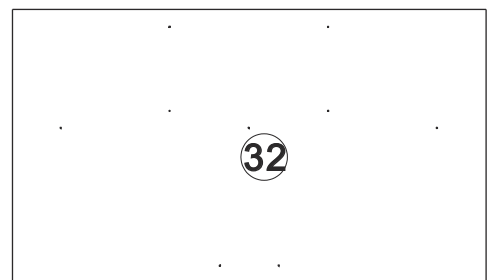

1410x814x3mm

# BOX 5/5

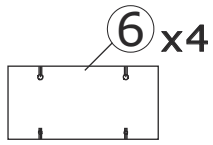

450x219x15mm



450x219x15mm

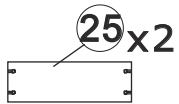

370x120x15mm

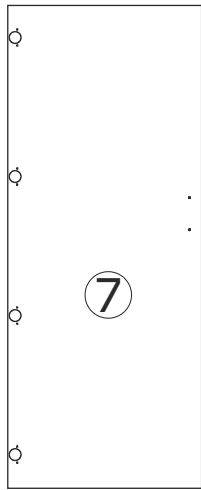

1445x580x15mm

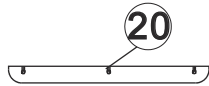

600x50x15mm

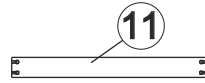

585x60x15mm

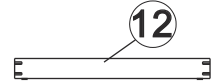

585x60x15mm

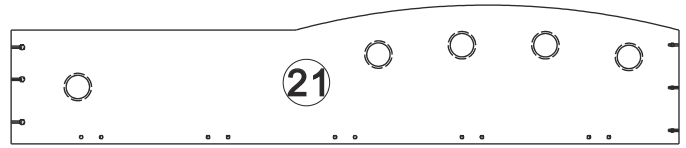

2000x415x18mm

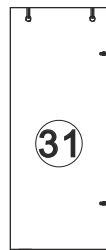

723x300x15mm

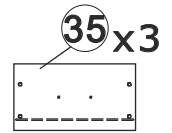

364x199x18mm

1

<b>Bx2</b>  <b>M6X10mm</b>	<b>Fx7</b>  <b>M6X40mm</b>	 
---	---	---

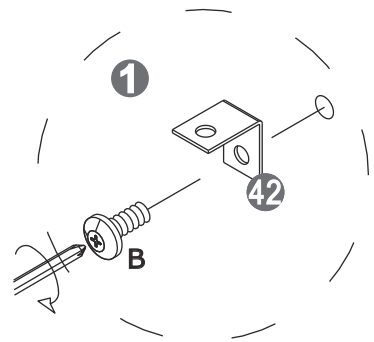
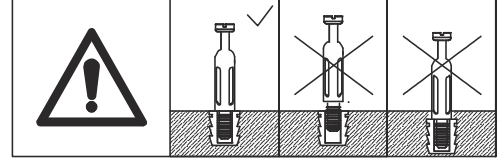
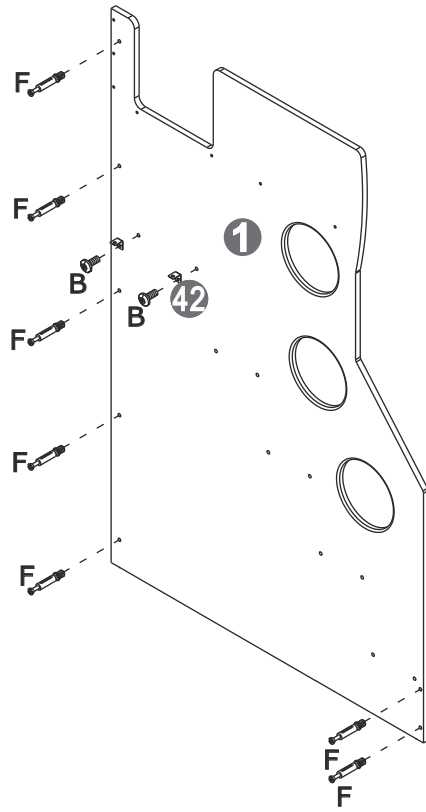

2

<b>Bx2</b>  <b>M6X10mm</b>	<b>Fx7</b>  <b>M6X40mm</b>	 
---	---	---

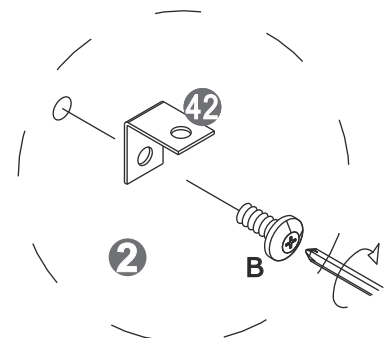
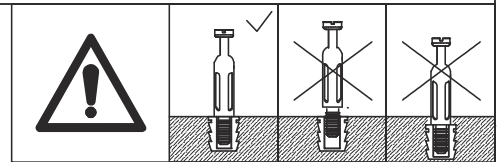
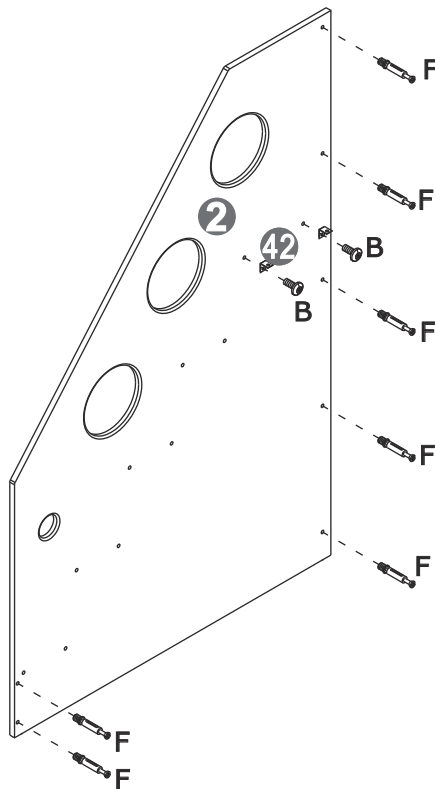

3

Gx7



Ø15X11.3mm

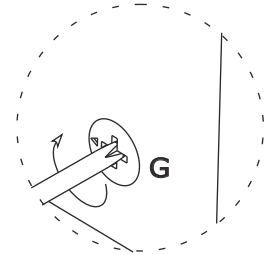
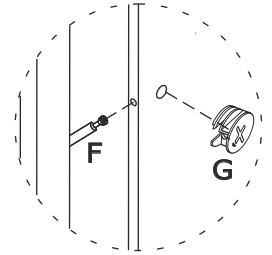
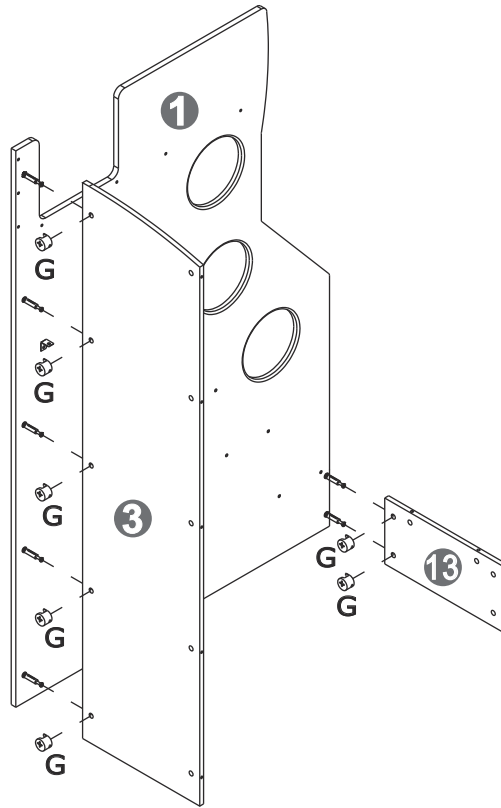
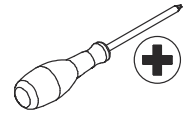

4

Gx7



Ø15X11.3mm

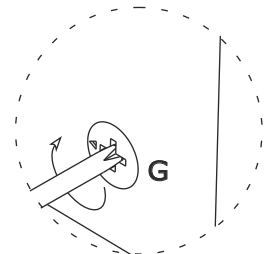
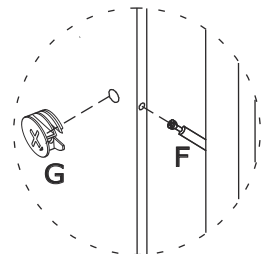
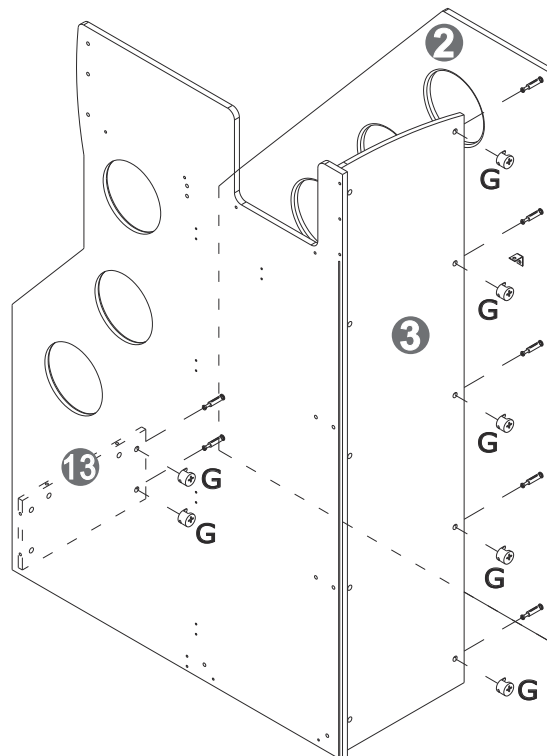
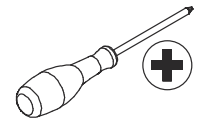

5

Bx4



M6X10mm

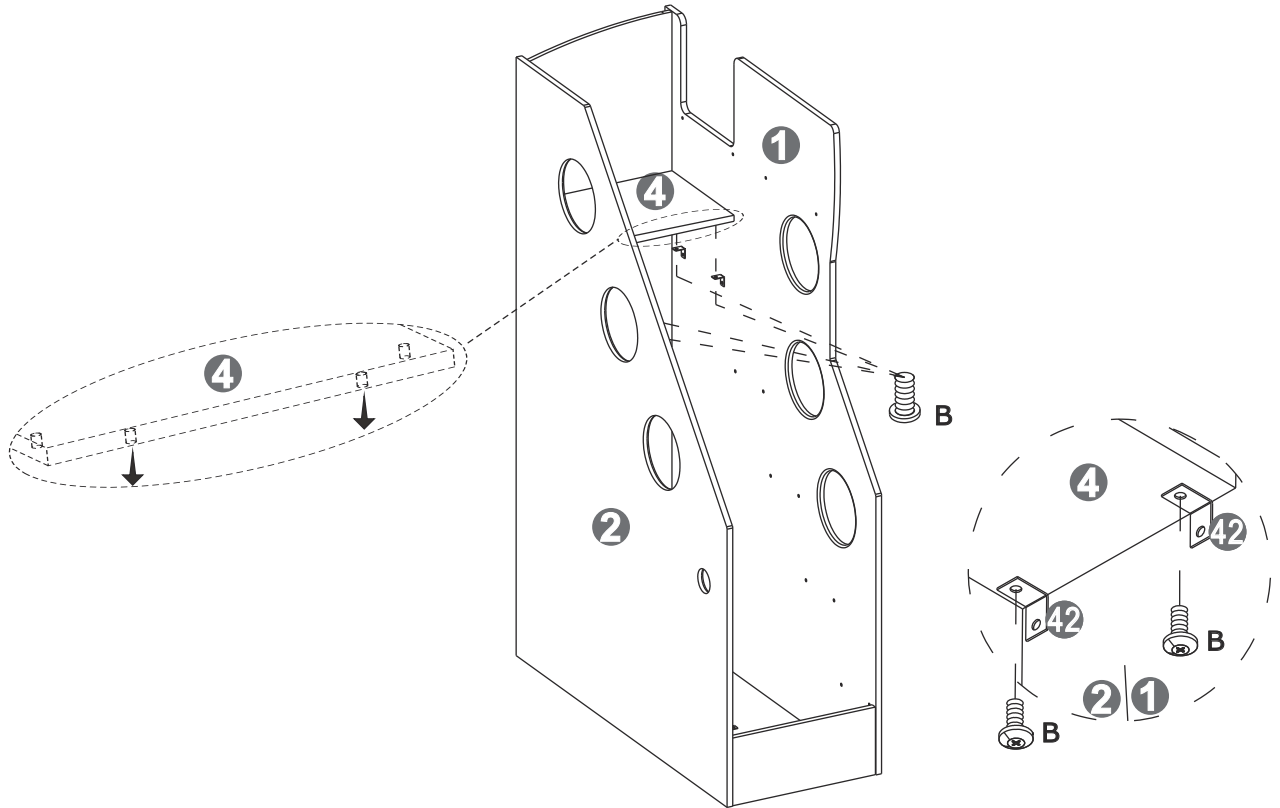
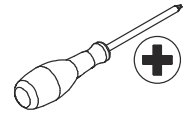

6

Fx2

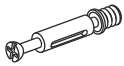

M6X40mm

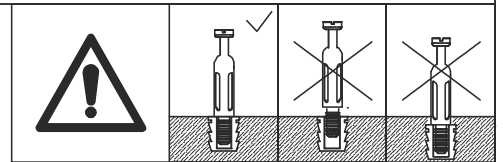
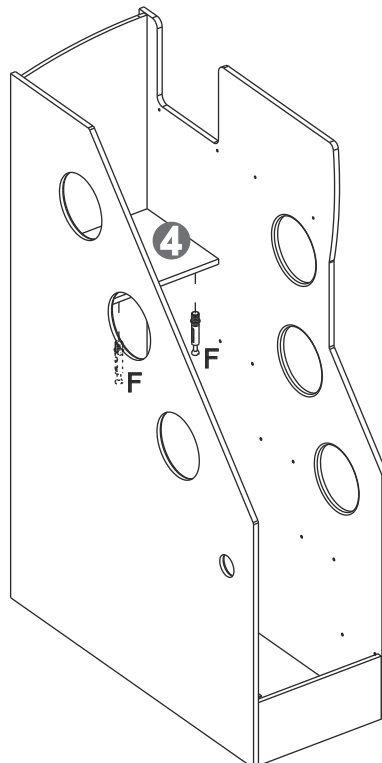
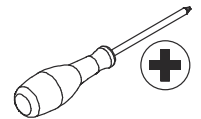

7

Gx2



Ø15X11.3mm

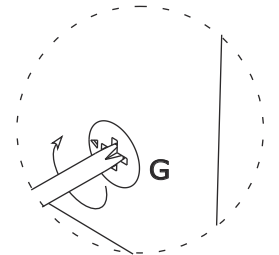
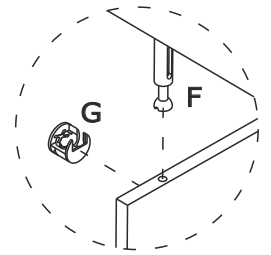
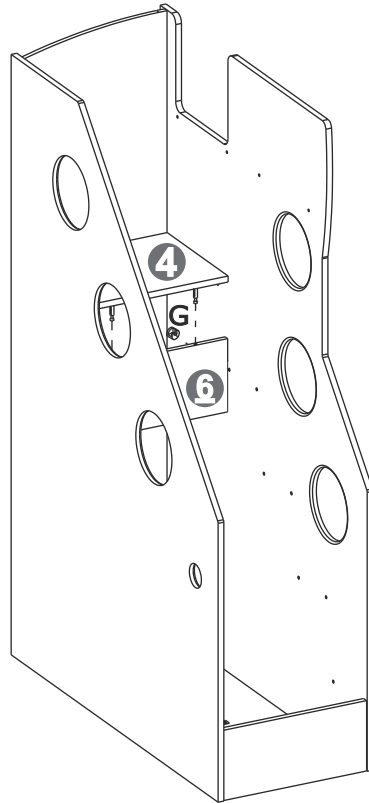
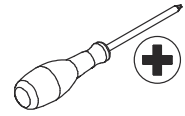

8

Ax2

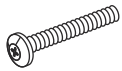

M6X45mm

Bx8



M6X10mm

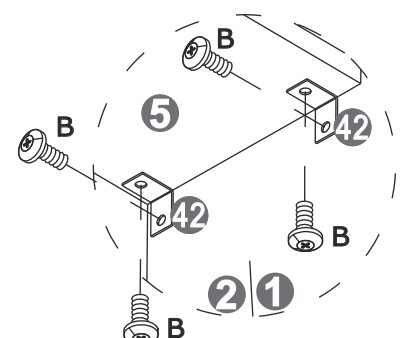
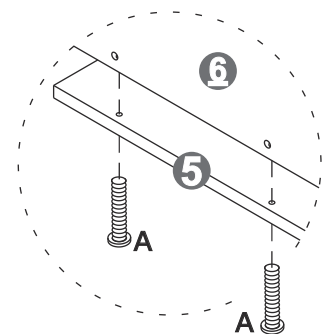
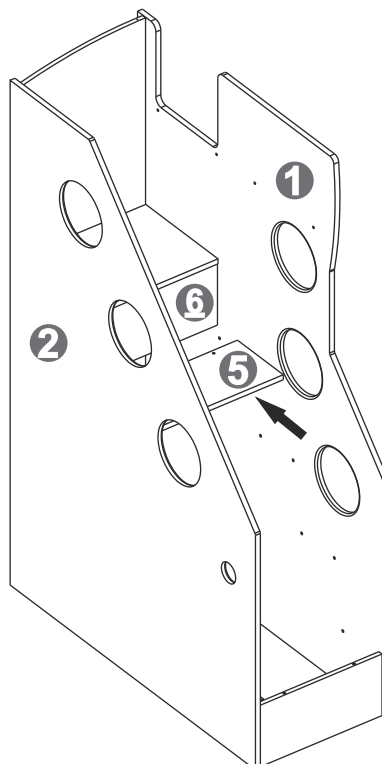
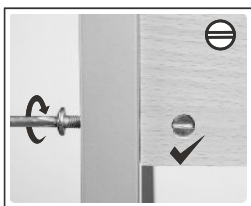
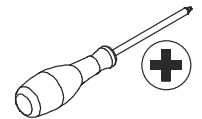

9

Fx2

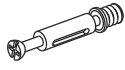

M6X40mm

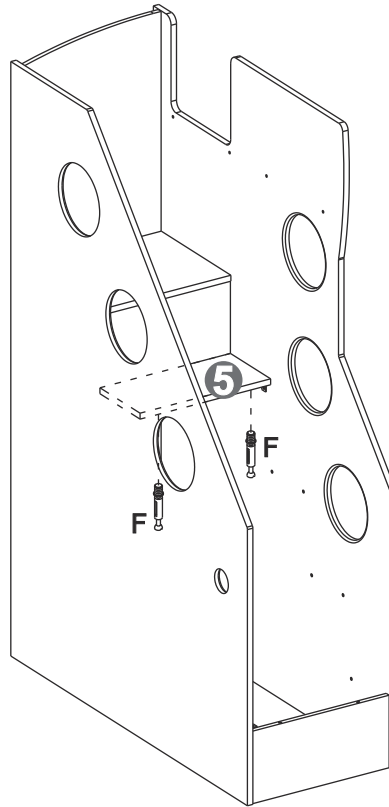
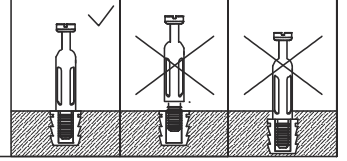
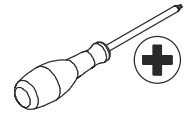

10

Gx2



Ø15X11.3mm

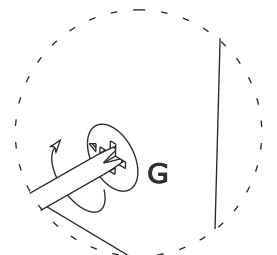
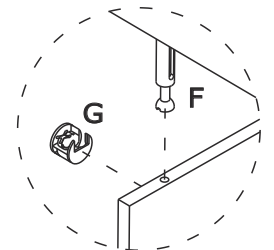
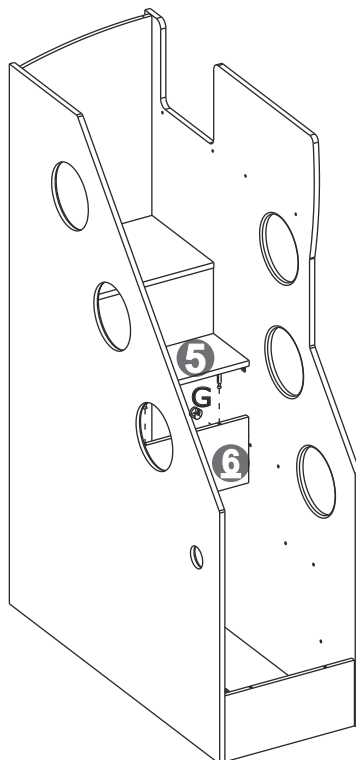
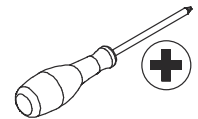

11

Bx12



M6X10mm

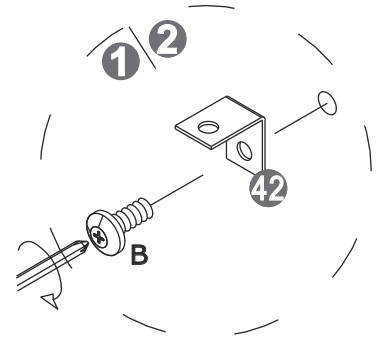
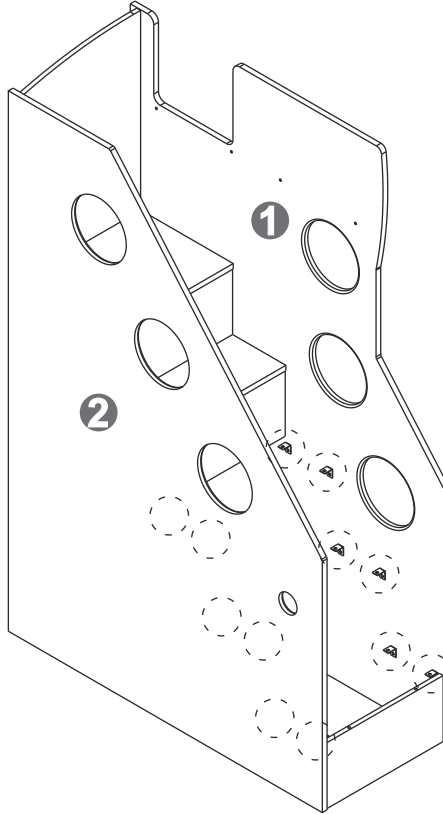
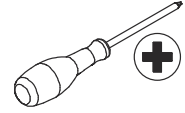

12

Fx6

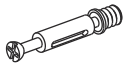

M6X40mm

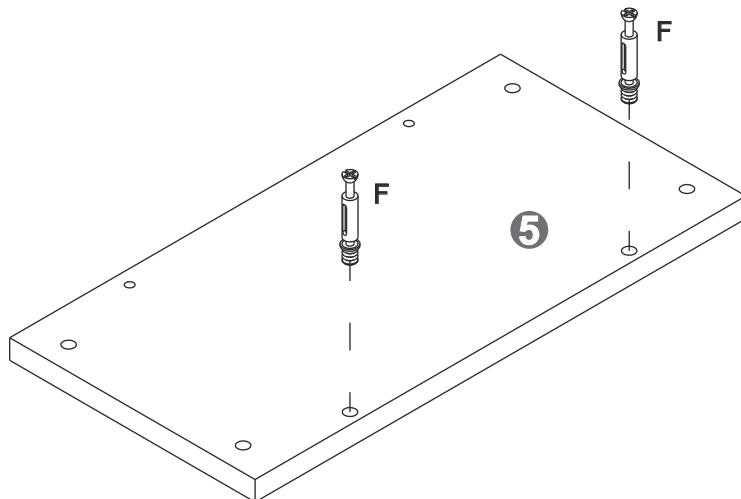
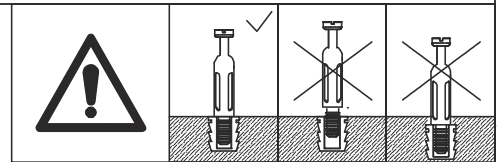
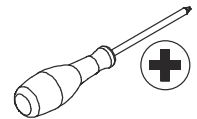

X3

13

Gx4



Ø15X11.3mm

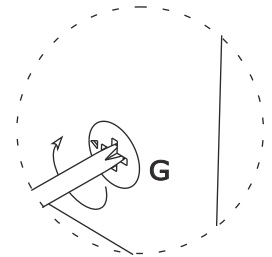
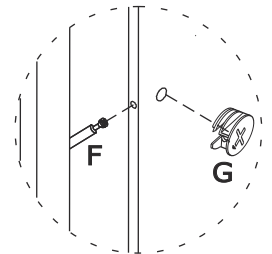
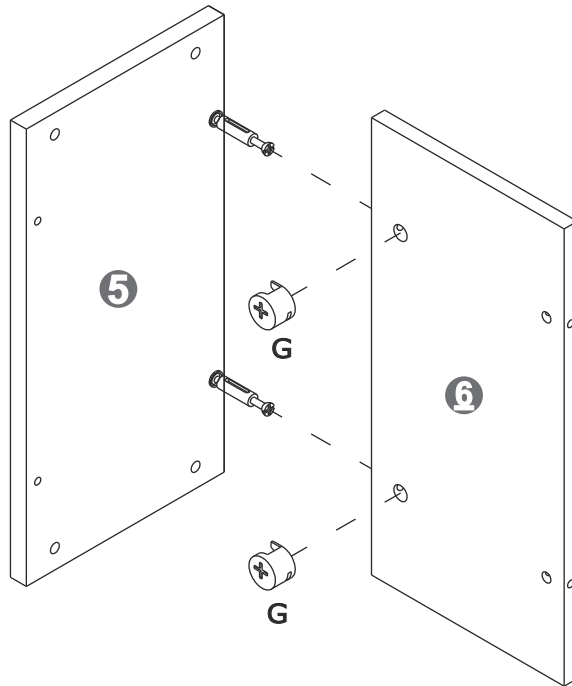
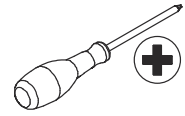

X2

14

Ax2

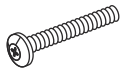

M6X45mm

Bx4



M6X10mm

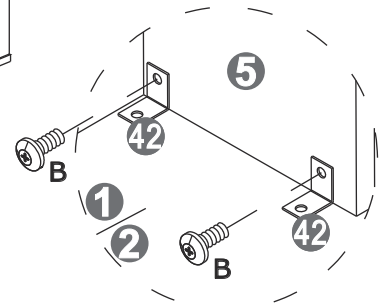
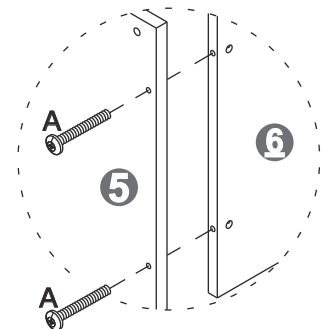
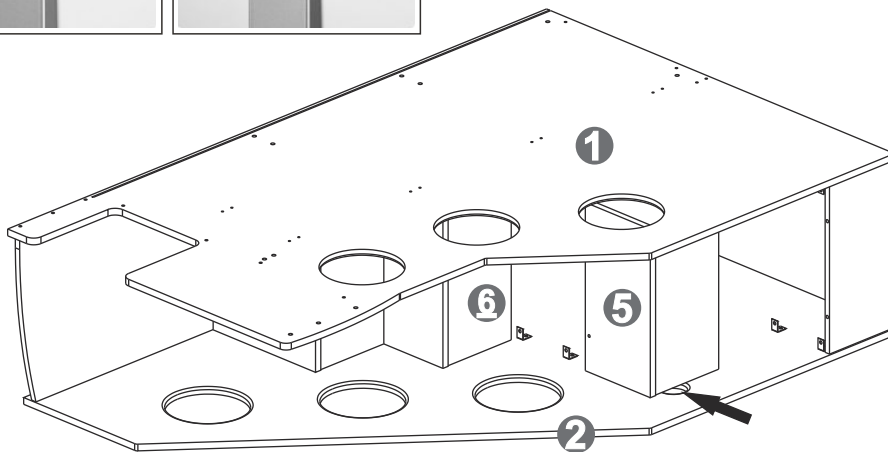
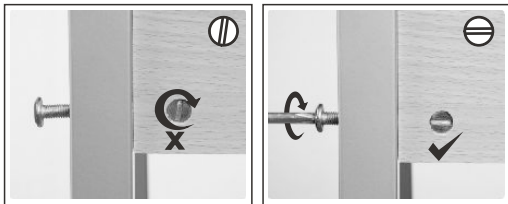
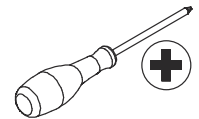

15

<b>Bx4</b>  M6X10mm	<b>Gx2</b>  Ø15X11.3mm	
--	---	---

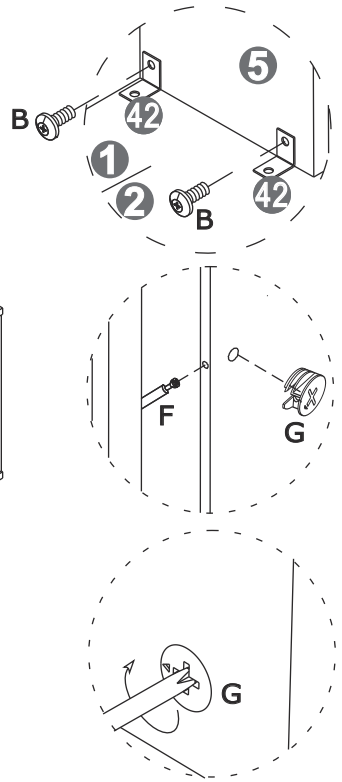
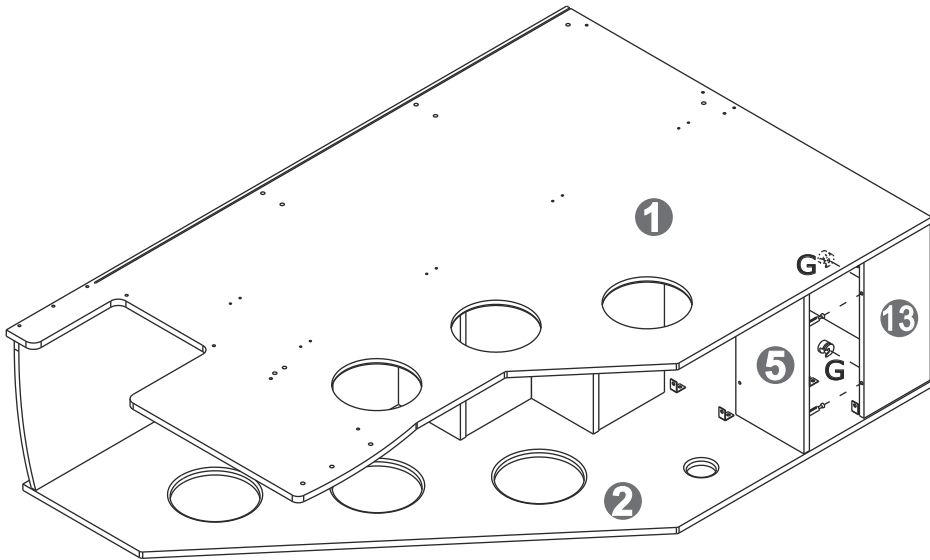

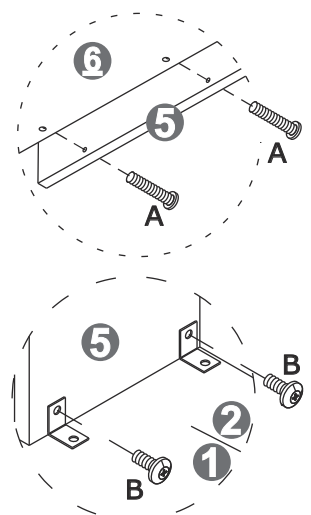
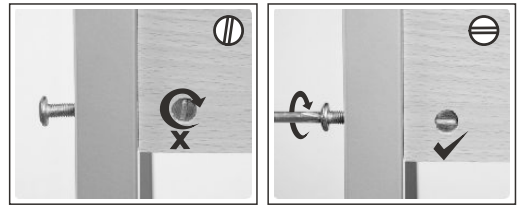
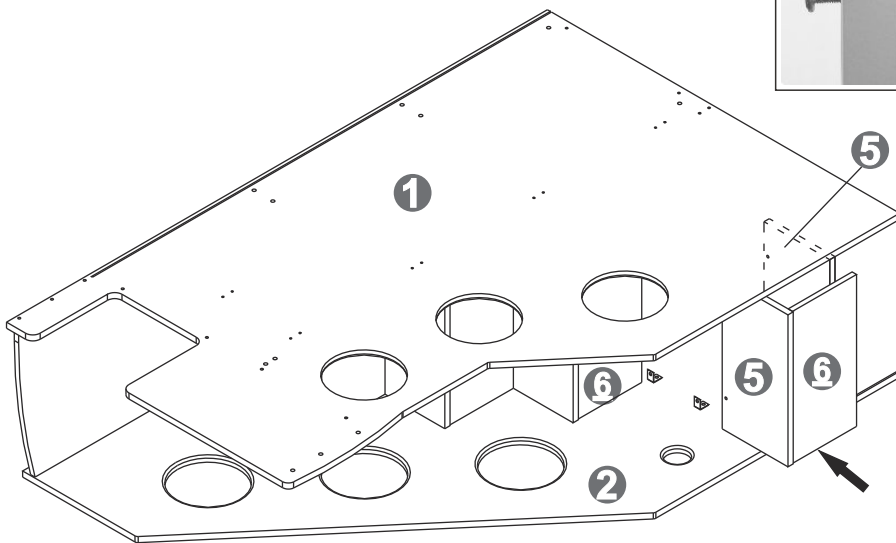

16

<b>Ax4</b>  M6X45mm	<b>Bx4</b>  M6X10mm	
--	--	---

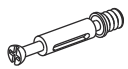

17

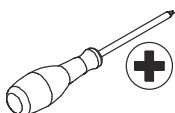
<b>Ex2</b>  3.5X14mm	<b>Fx5</b>  M6X40mm	<b>Hx6</b>  M6X25mm	<b>Lx1</b> 	
---	--	--	---	---

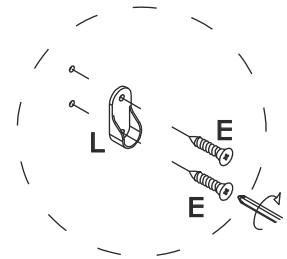
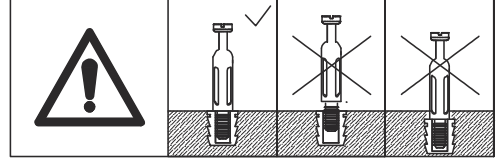
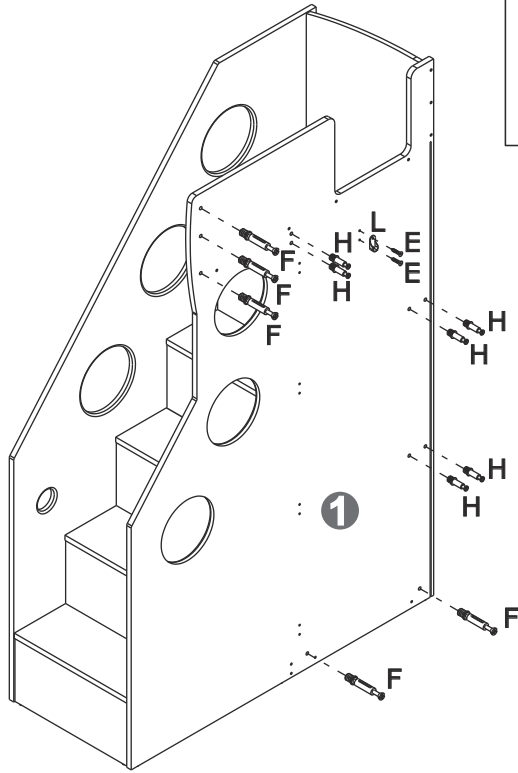

18

<b>Jx8</b>  Ø6X30mm	
--	---

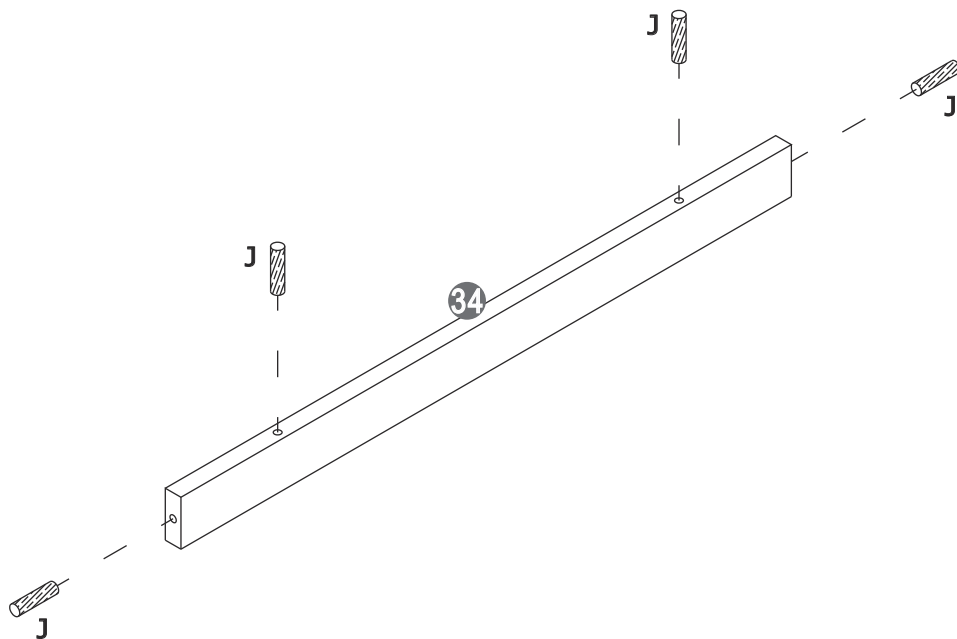

X2

19

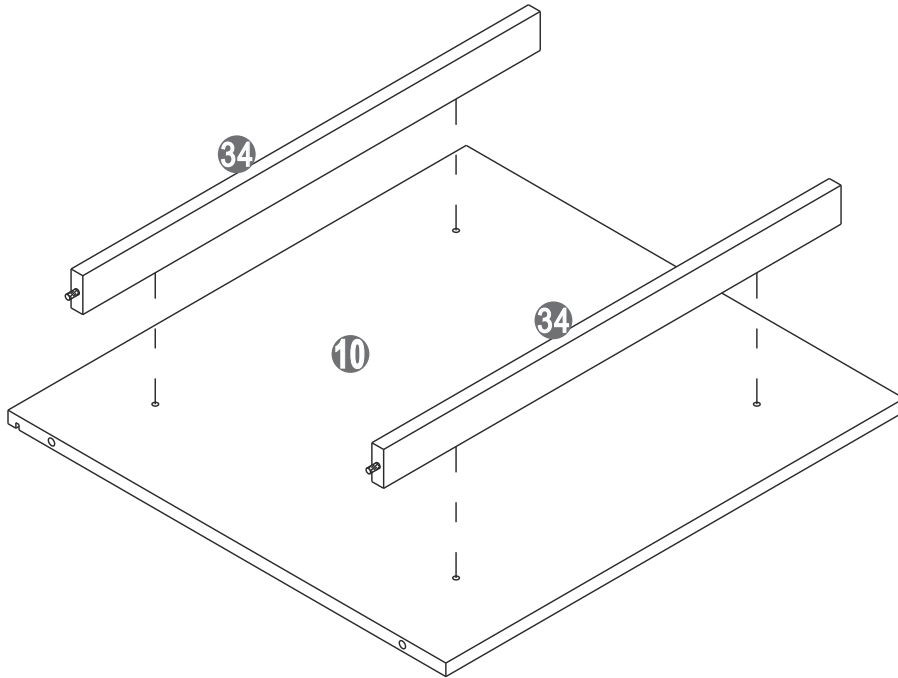

20

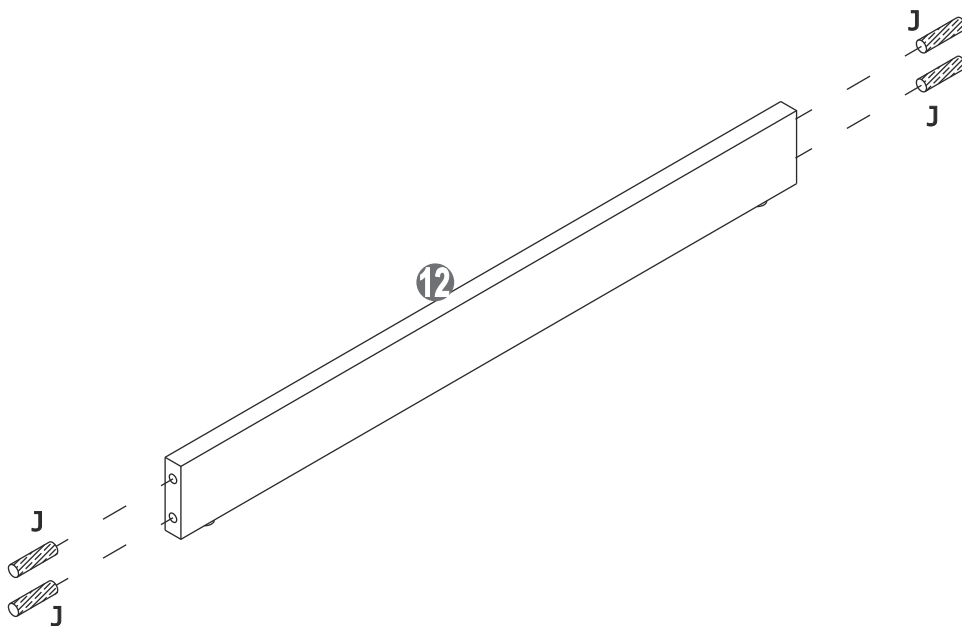

21

Gx2



Ø15X11.3mm

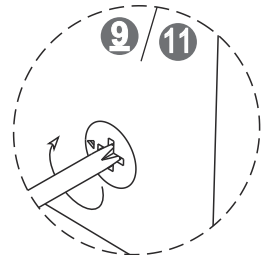
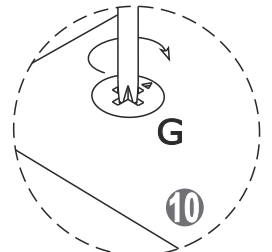
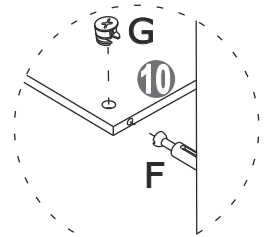
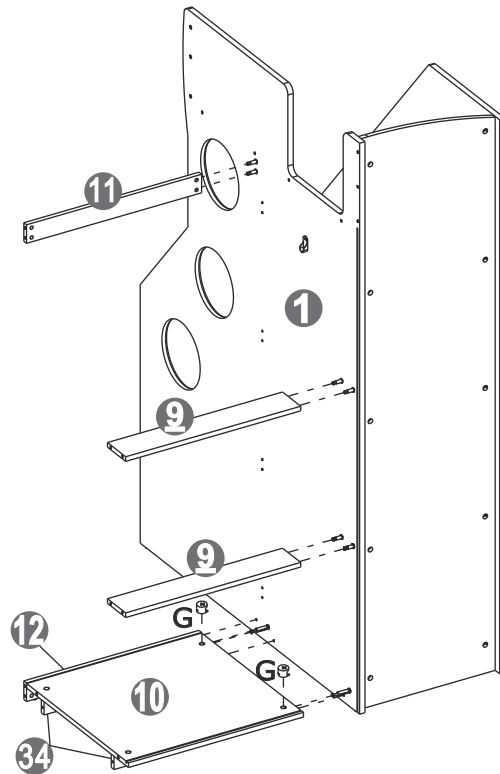
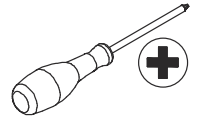

22

Ex11



3.5X14mm

Fx2

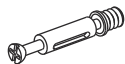

M6X40mm

Hx10



M6X25mm

Lx1

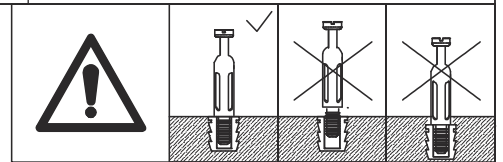
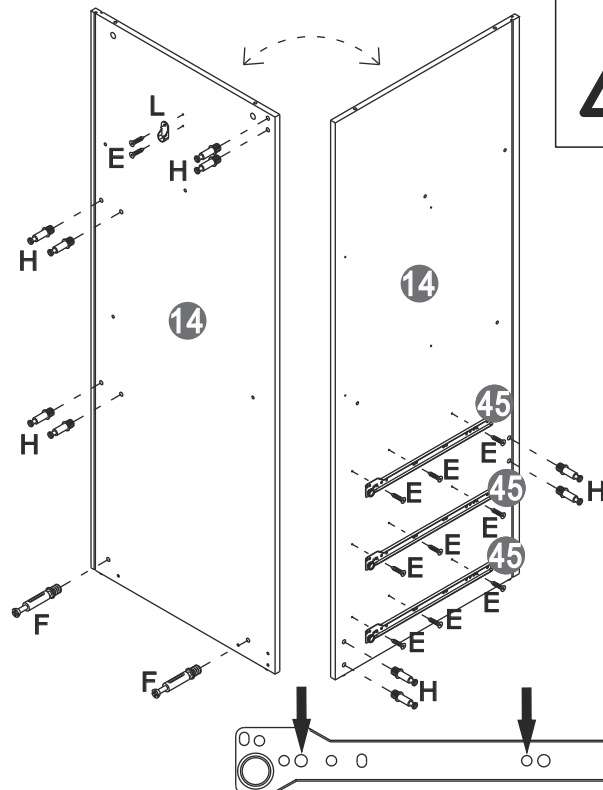
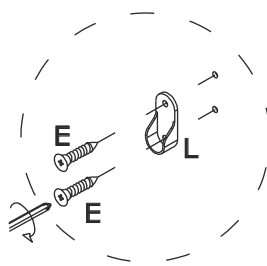
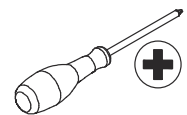

23

Gx2



Ø15X11.3mm

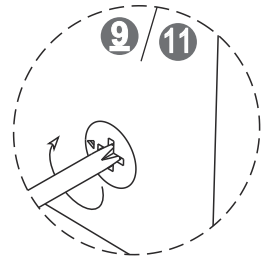
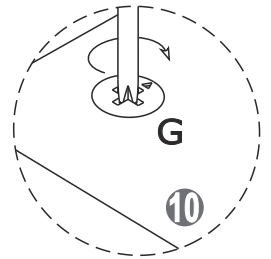
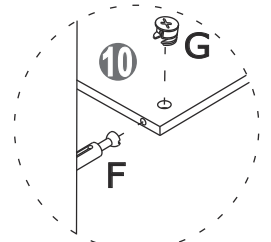
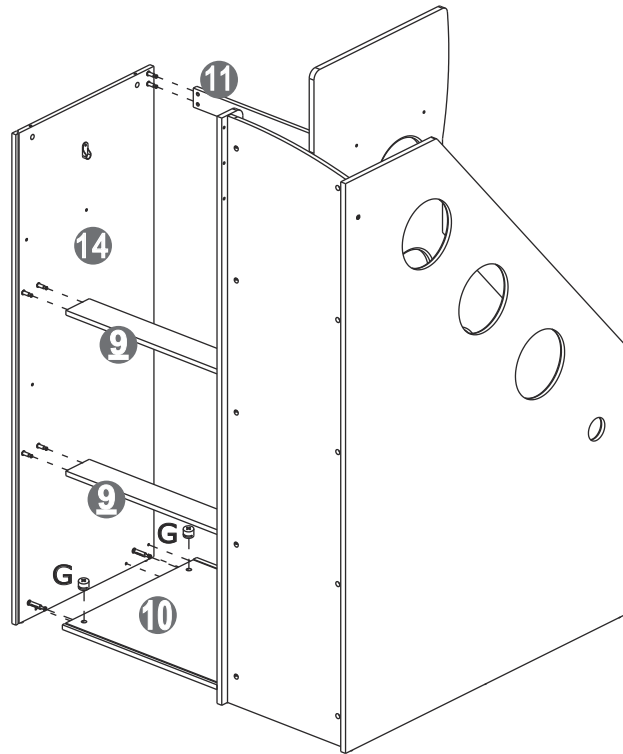
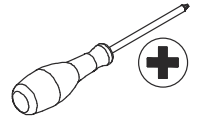

24

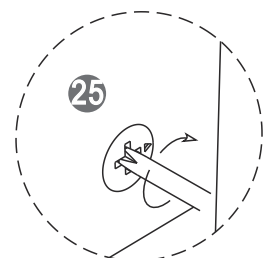
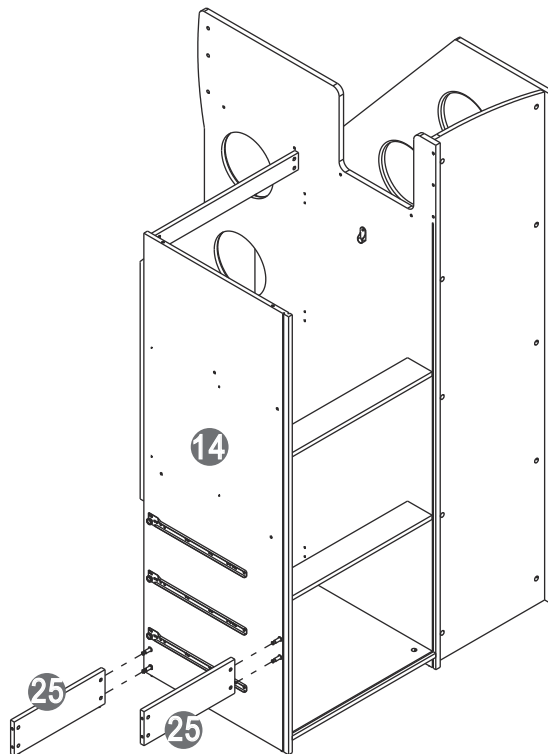
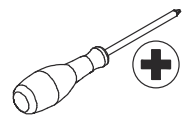

25

Ex9



3.5X14mm

Hx4



M6X25mm

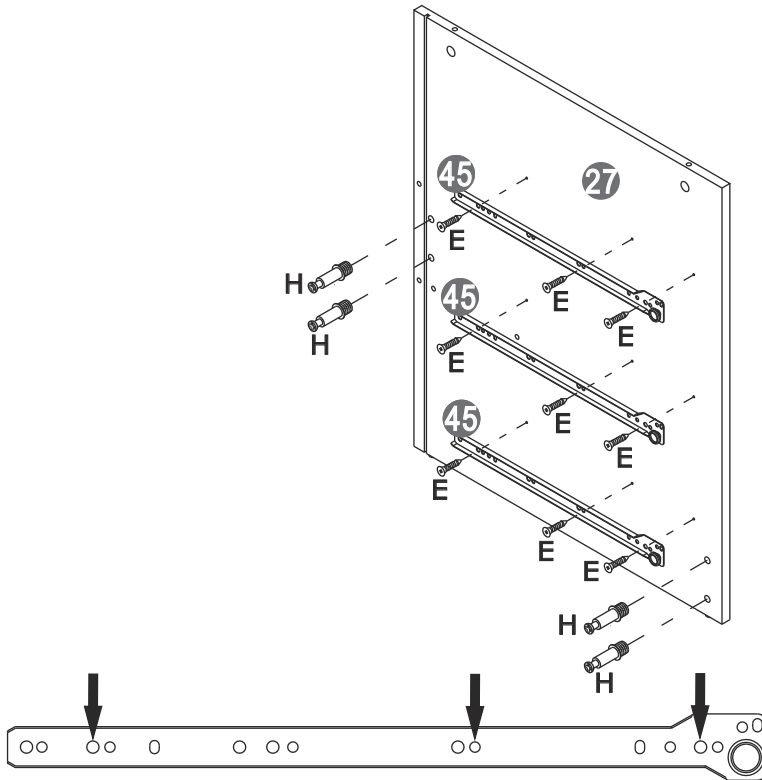
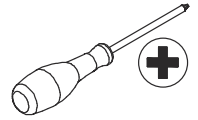

26

Ax2

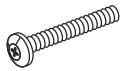

M6X45mm

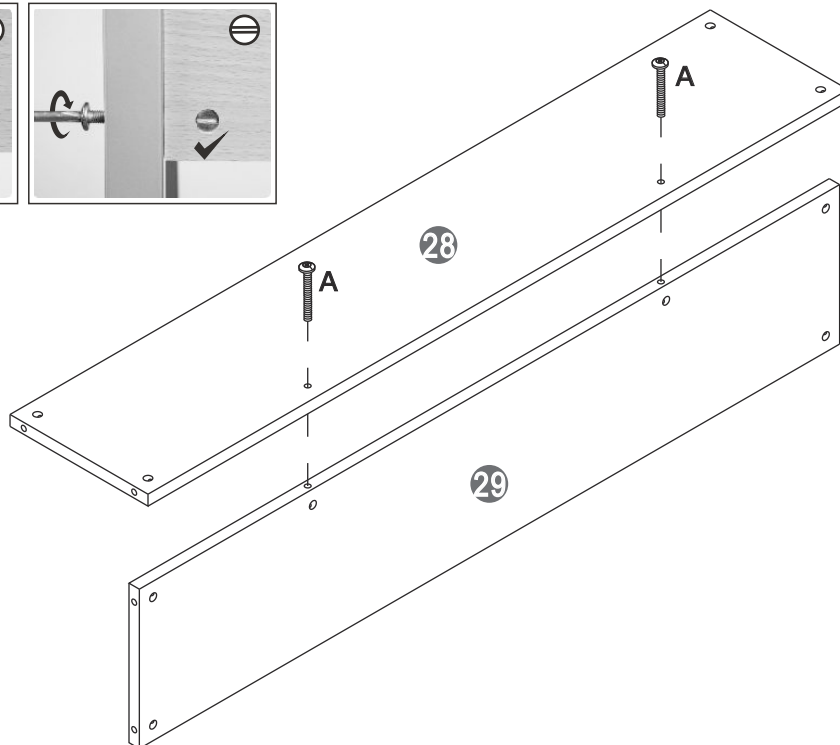
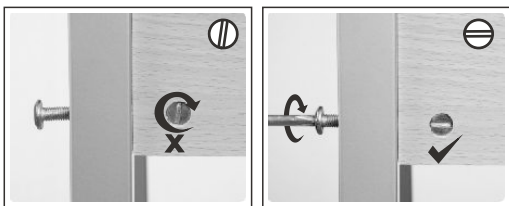
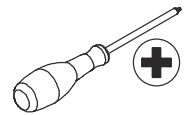

27

Ax4

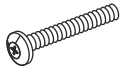

M6X45mm

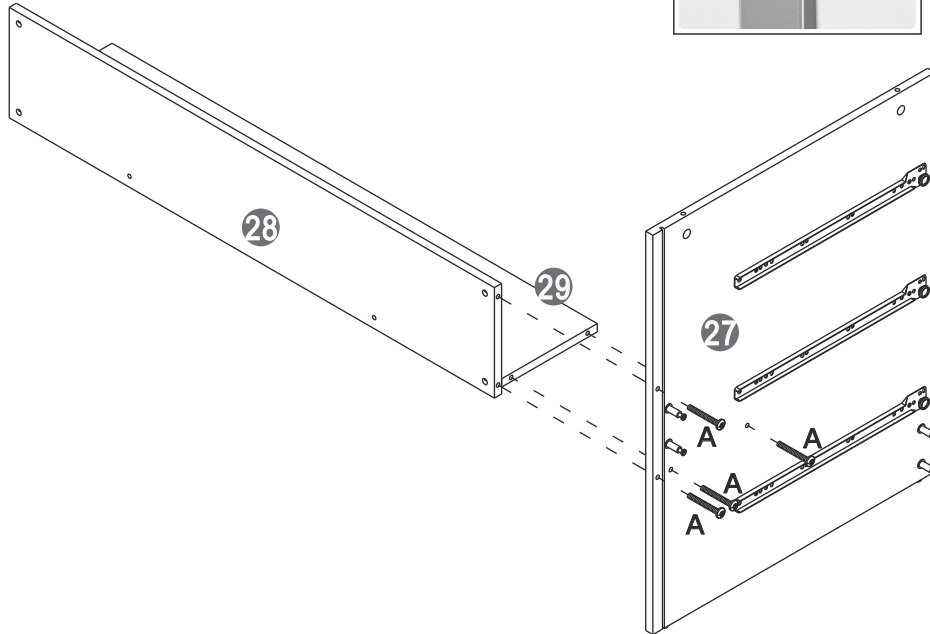
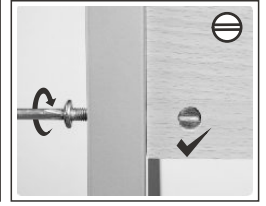
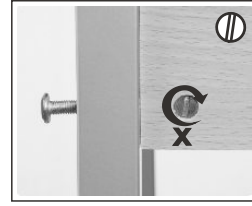
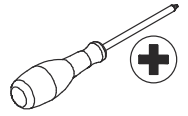

28

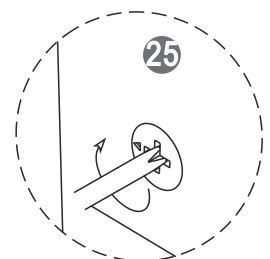
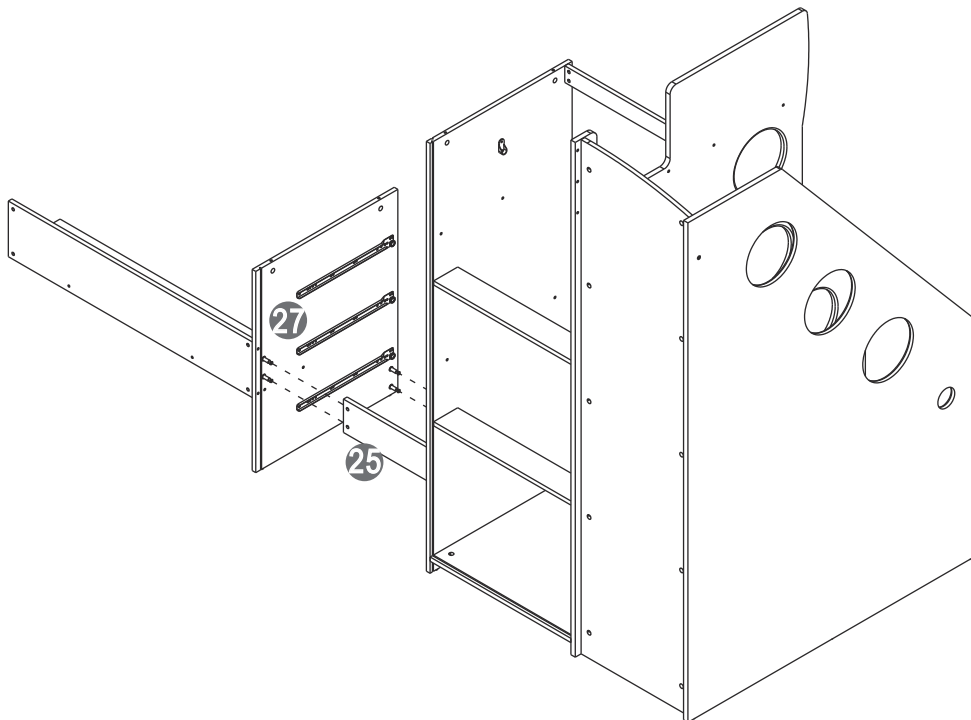
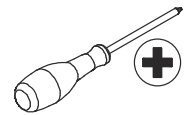

29

Fx4

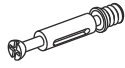

M6X40mm

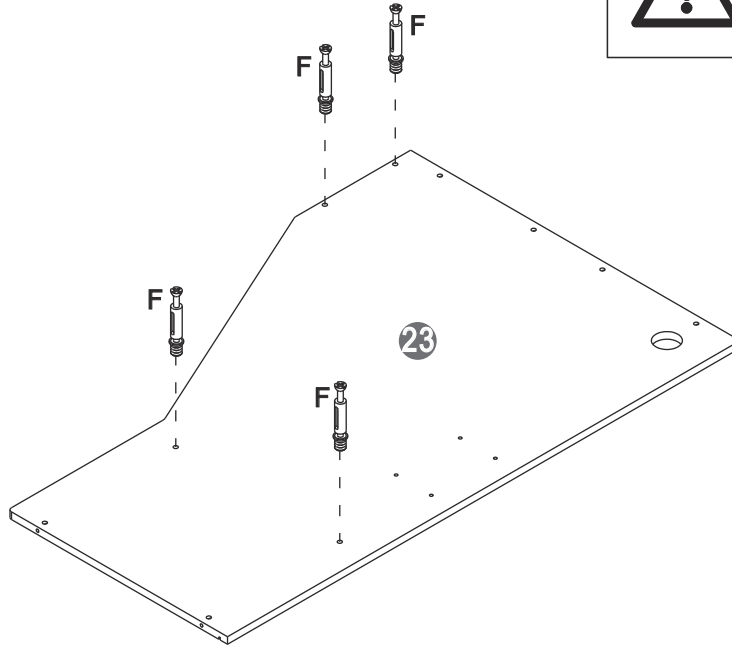
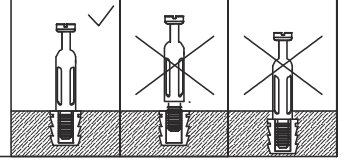
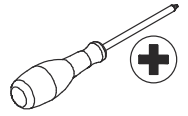

30

Gx2



Ø15X11.3mm

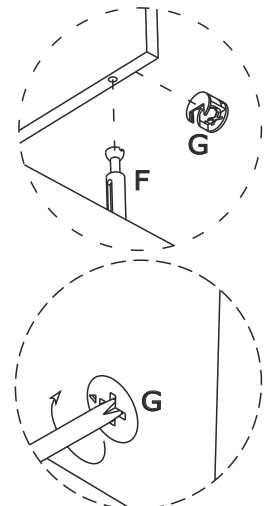
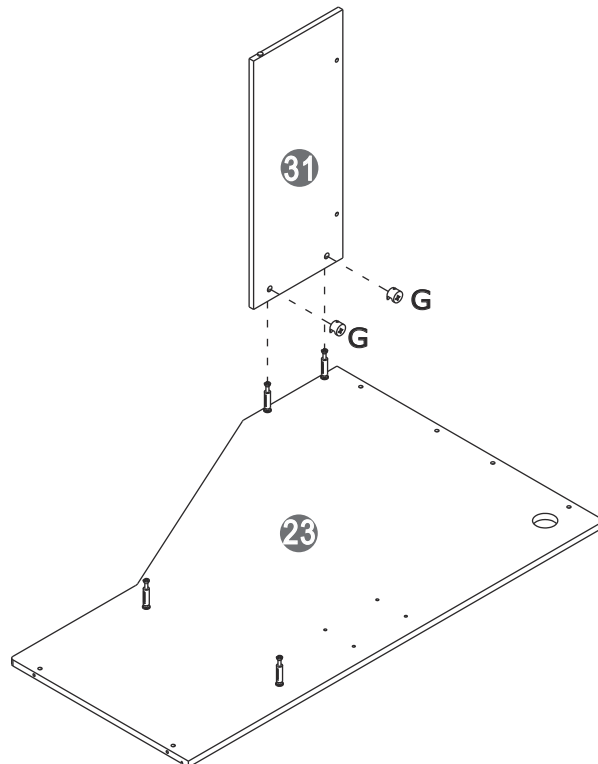
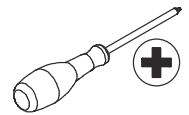

31

Ex2



3.5X14mm

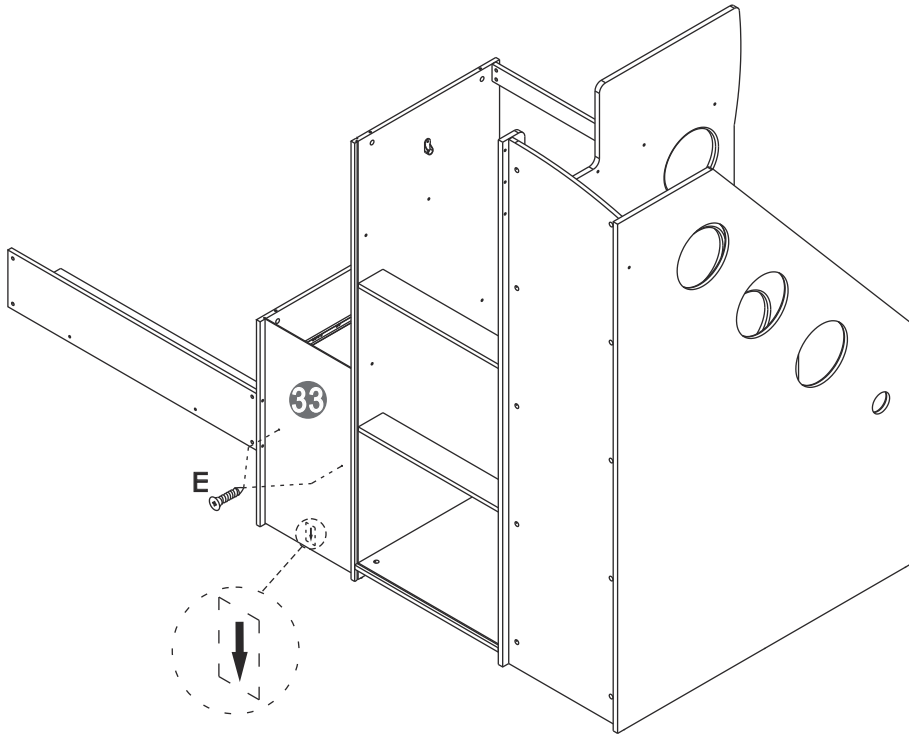
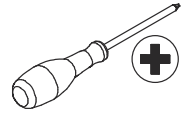

32

Gx2



Ø15X11.3mm

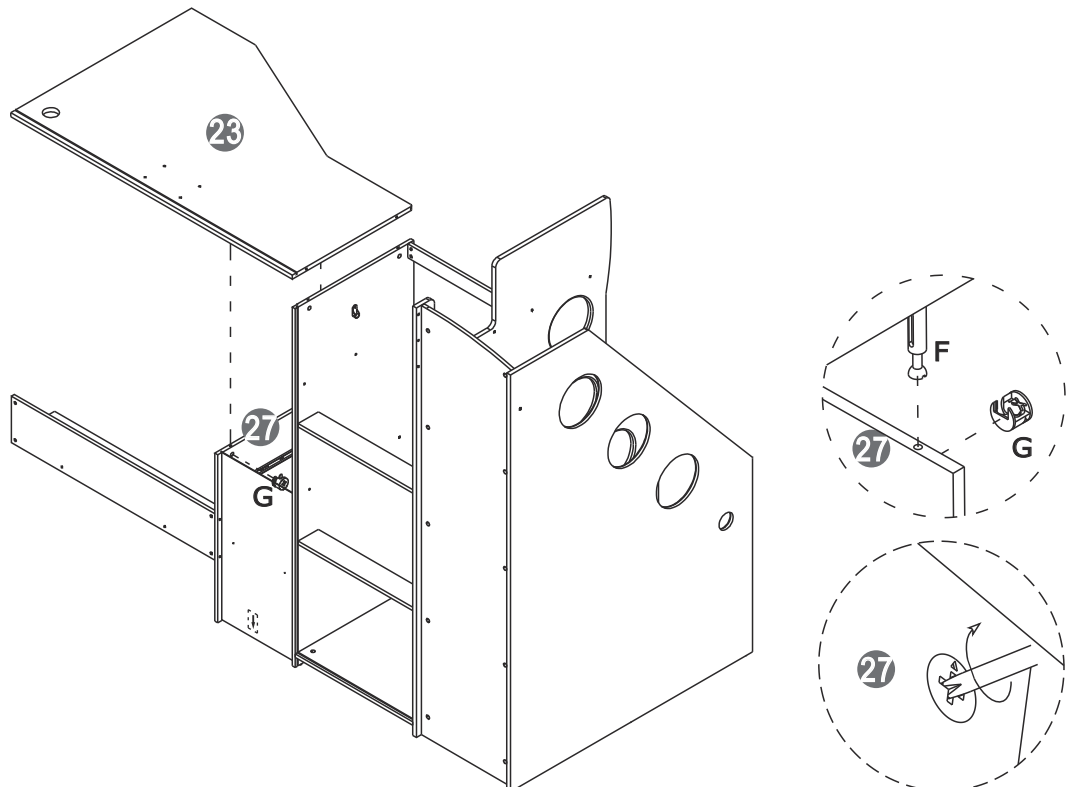
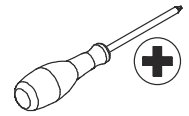

33

Ax2

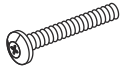

M6X45mm

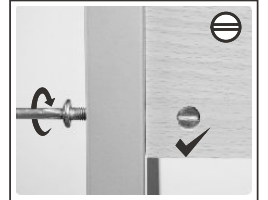
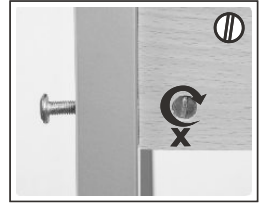
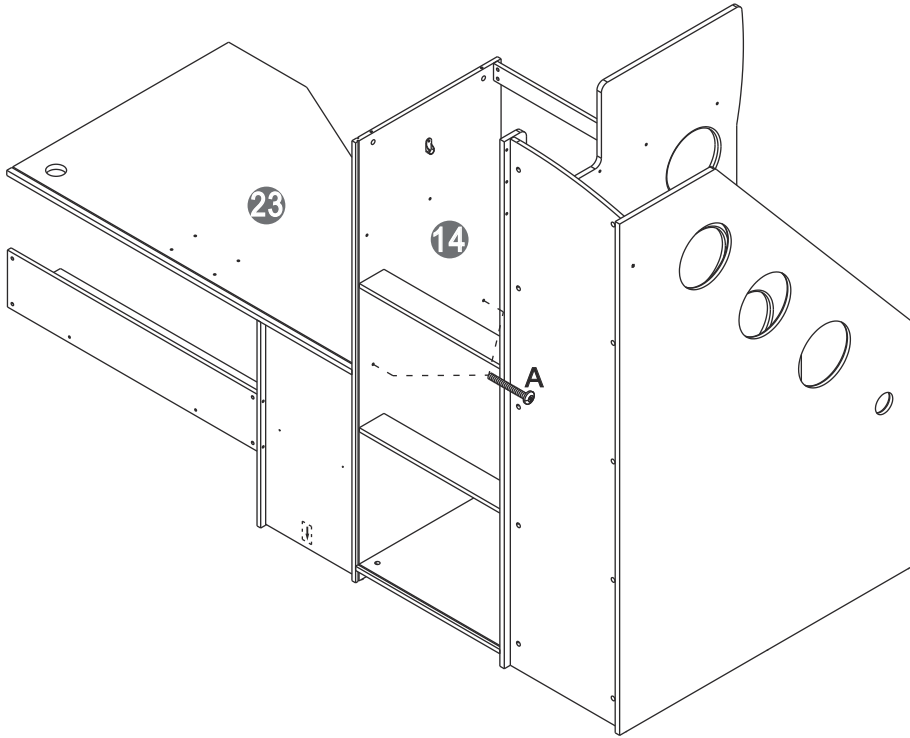
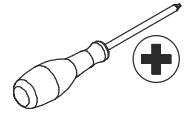

34

Jx8



Ø6X30mm

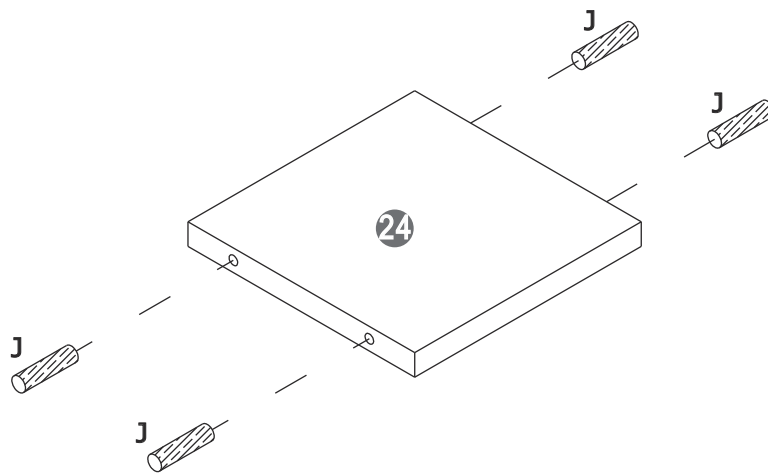
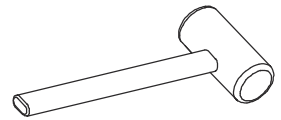

X2

35

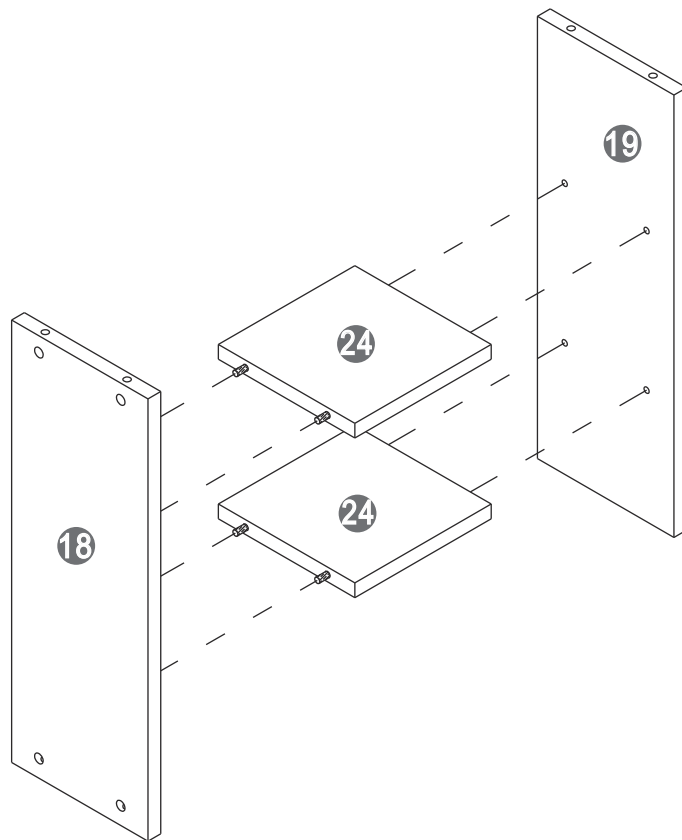

36

<p>Hx7  M6X25mm</p>	
--	---

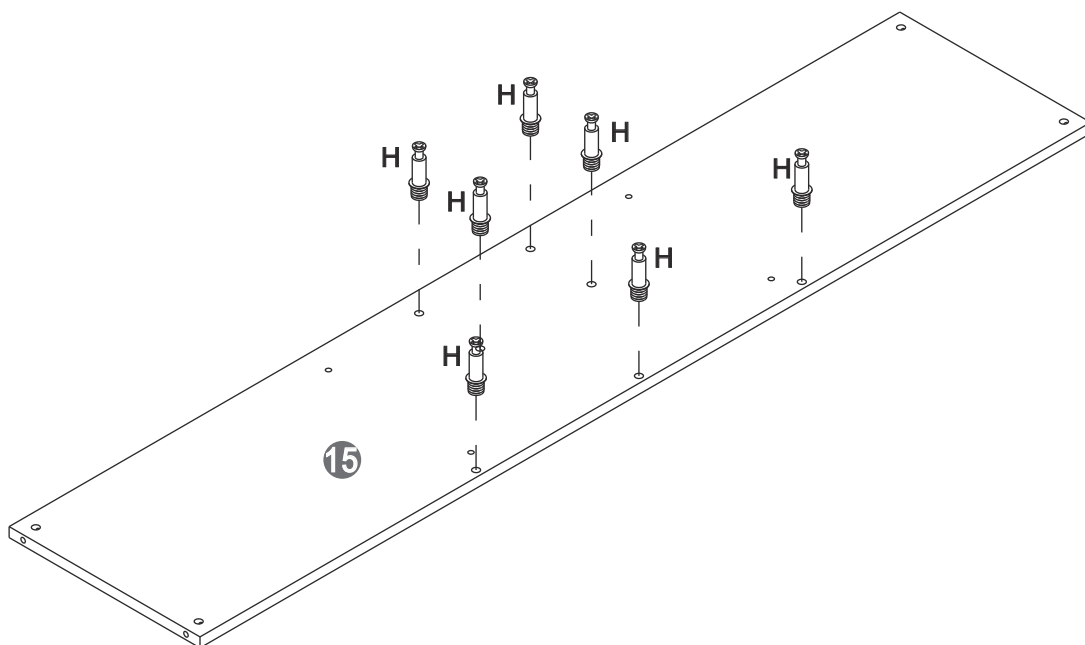

37

Ax4

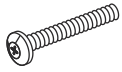

M6X45mm

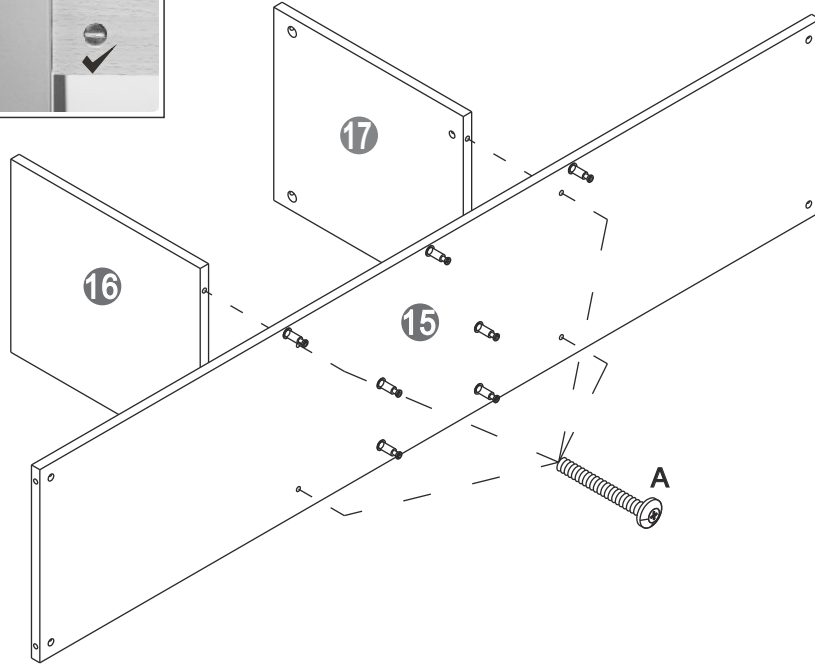
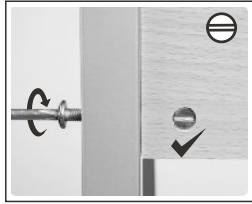
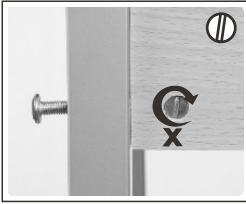
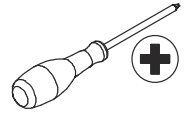

38

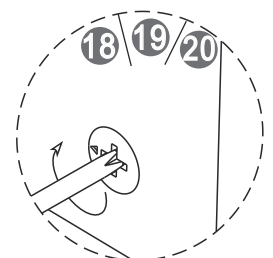
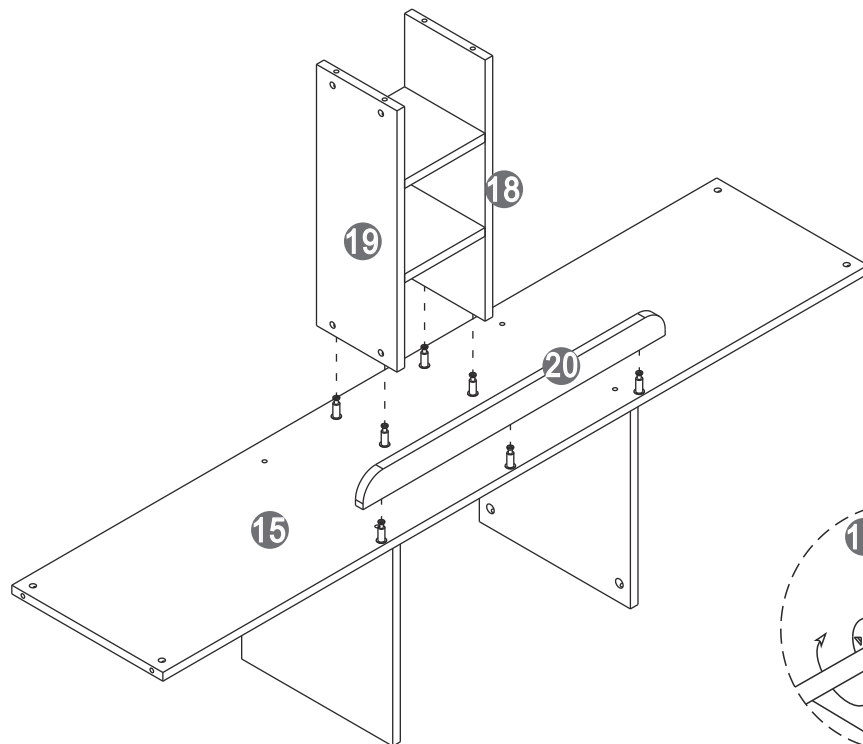
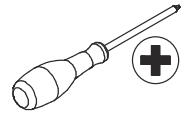

39

Ax6

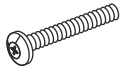

M6X45mm

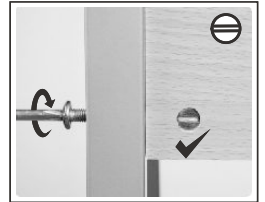
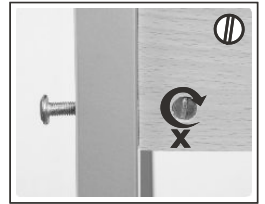
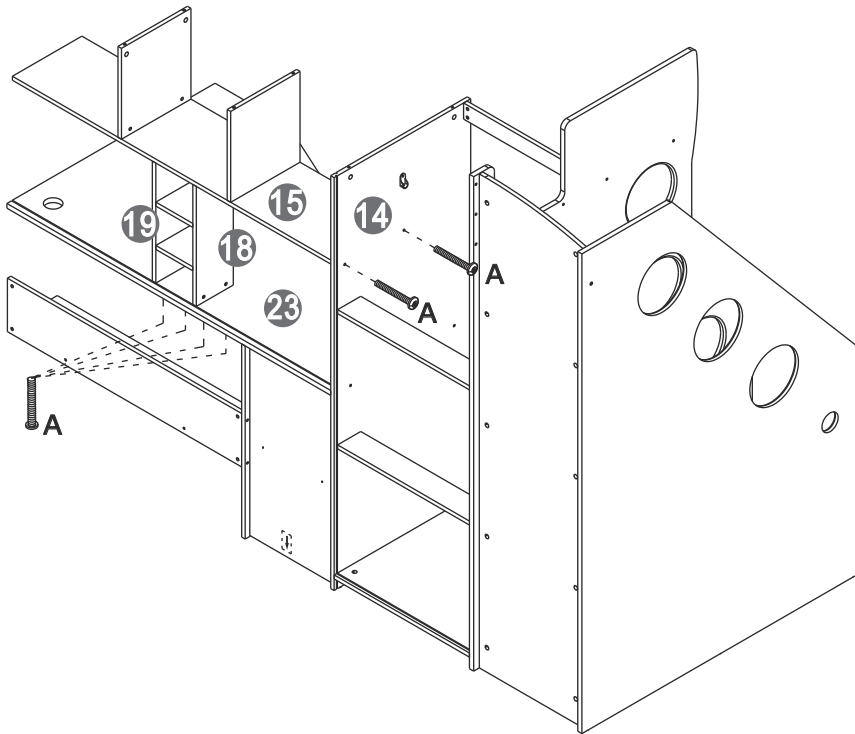
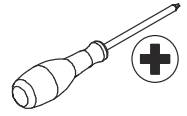

40

Px1



Ø60mm

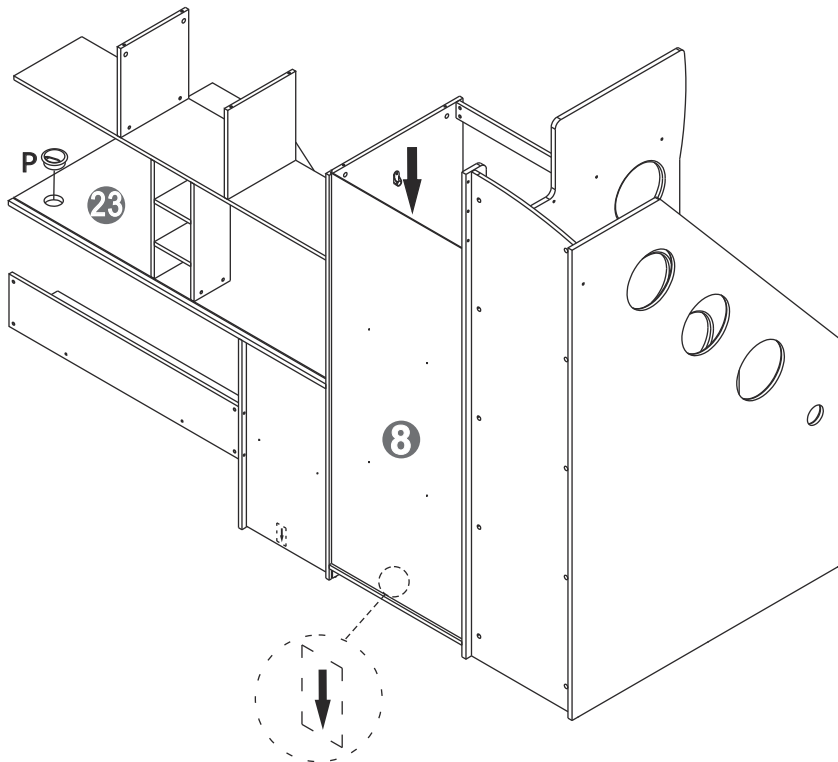

41

<b>Bx10</b>  M6X10mm	<b>Fx6</b>  M6X40mm	
---	--	---

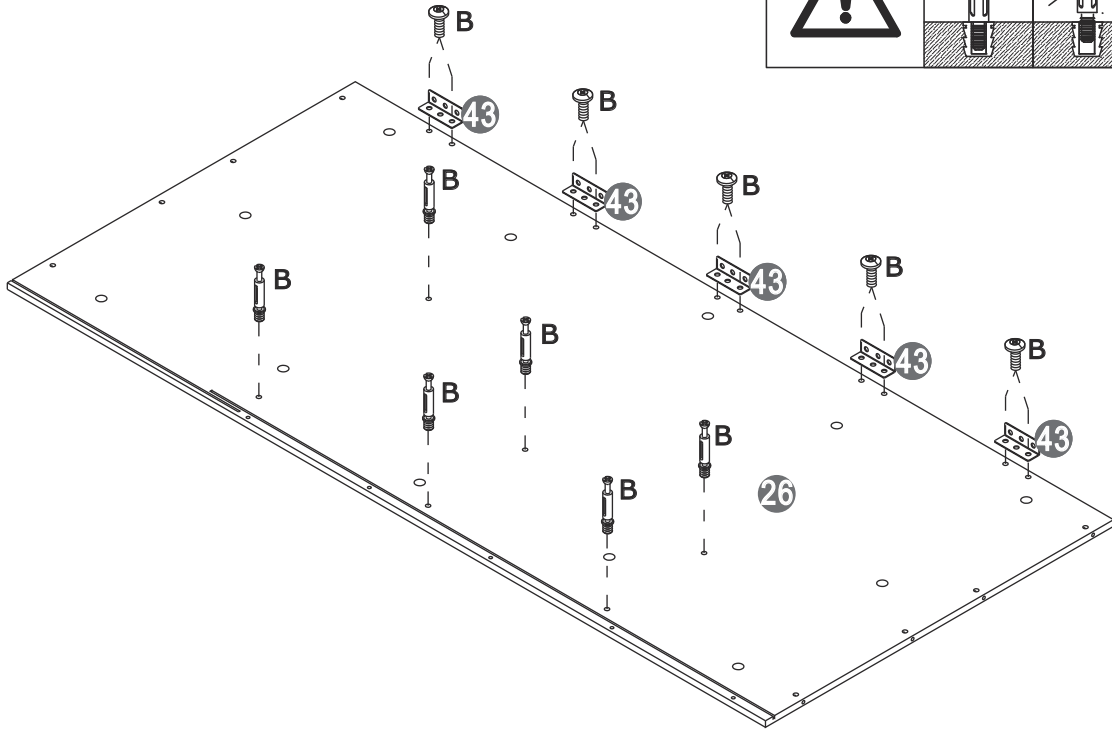
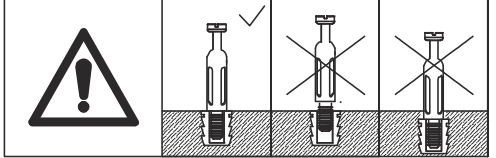

42

<b>Ax4</b>  M6X45mm	<b>Gx6</b>  Ø15X11.3mm	
--	---	---

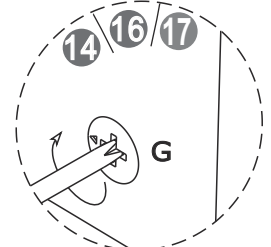
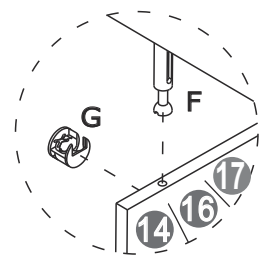
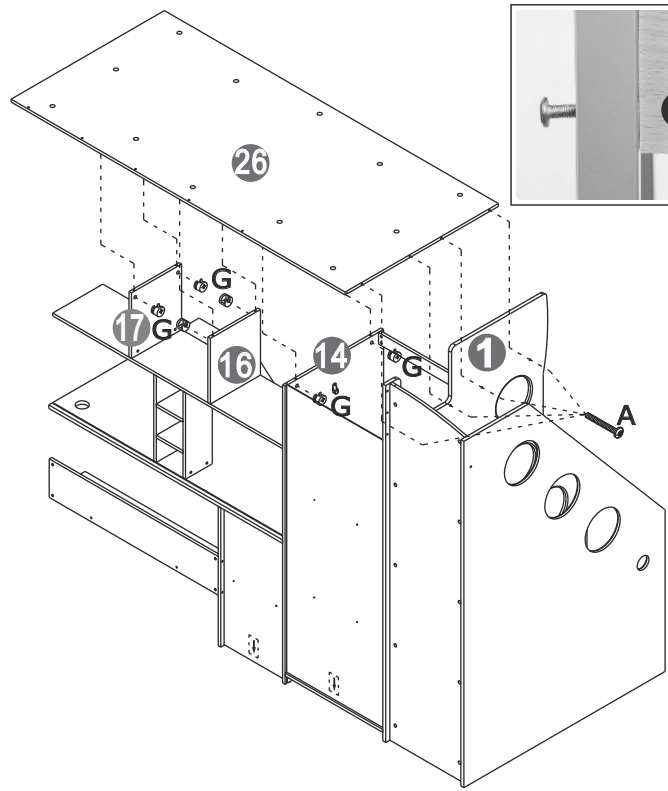
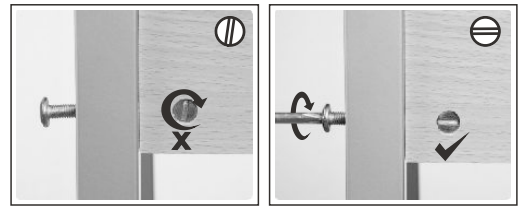

43

Ax8



M6X45mm

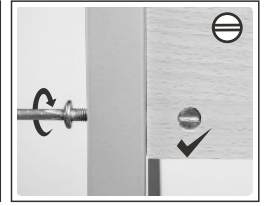
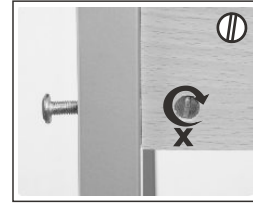
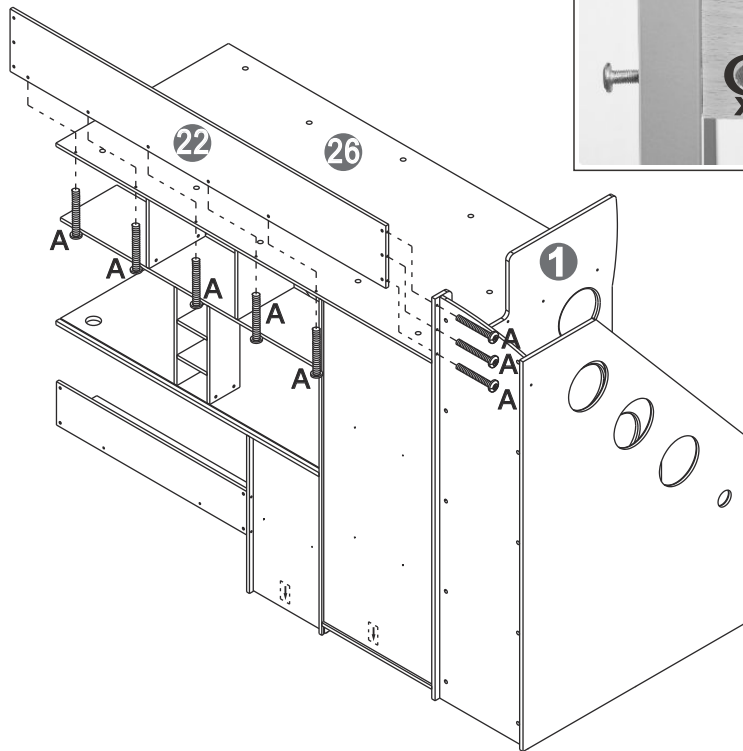
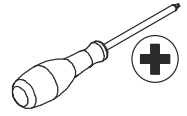

44

Bx10



M6X10mm

Gx3



Ø15X11.3mm

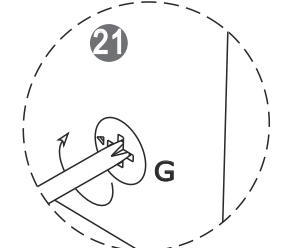
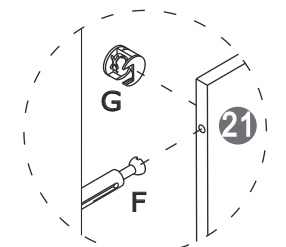
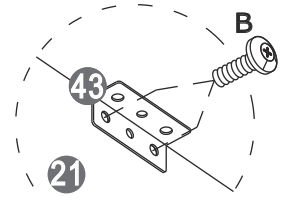
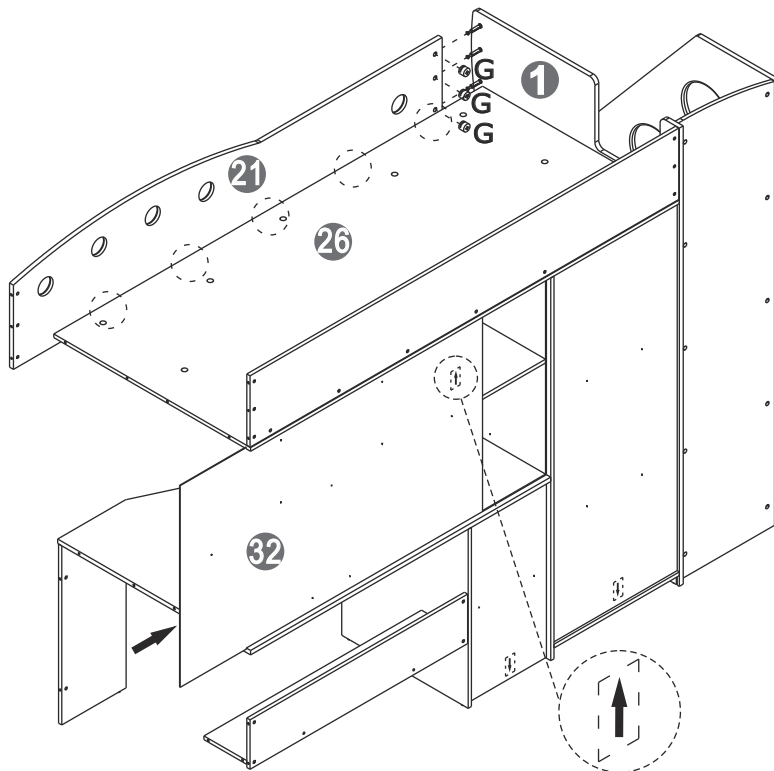
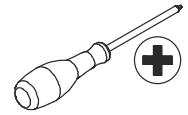

45

Ax22

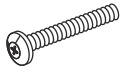

M6X45mm

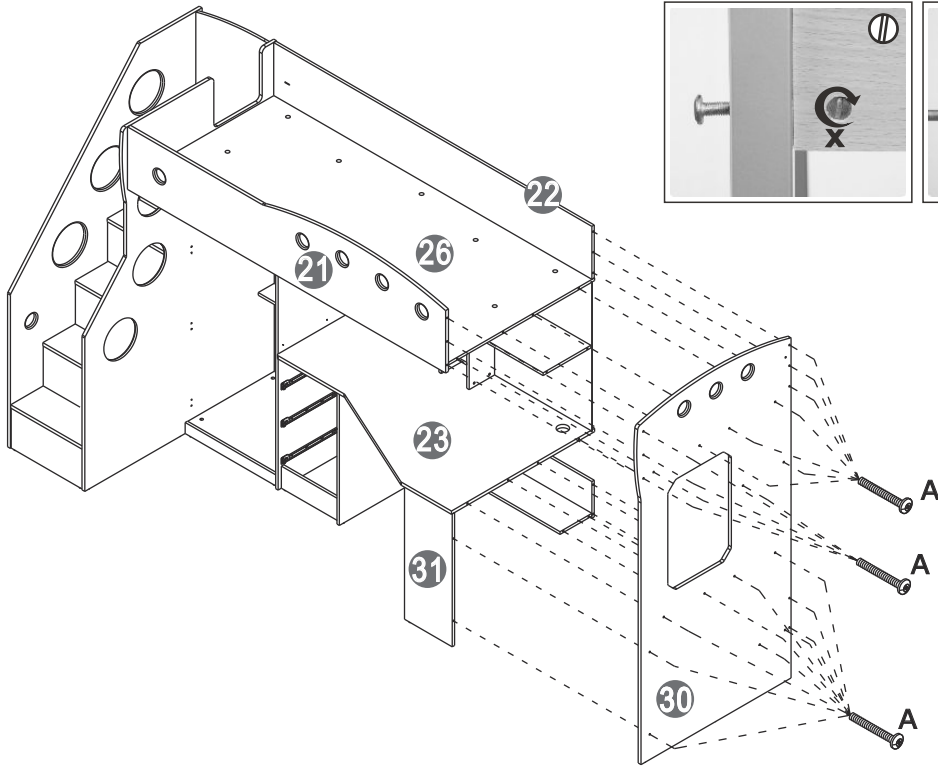
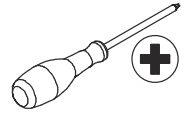

46





Ex13

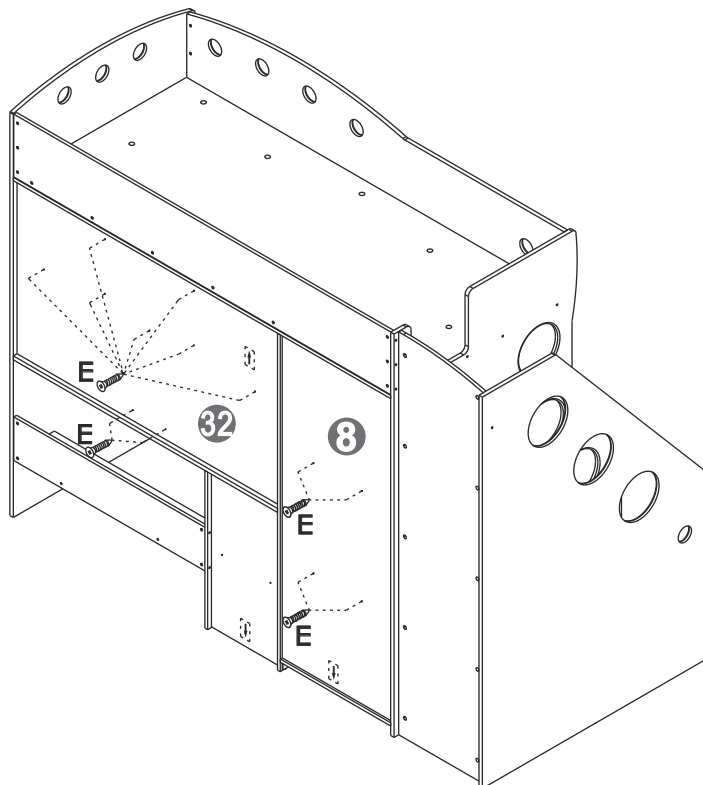
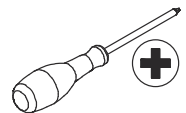

3.5X14mm

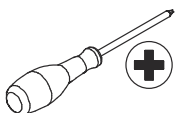

47

<b>Dx2</b>  M4X18mm	<b>Ex8</b>  3.5X14mm	<b>Mx4</b> 	<b>Nx1</b> 	
--	---	---	---	---

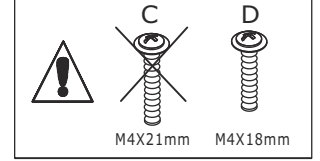
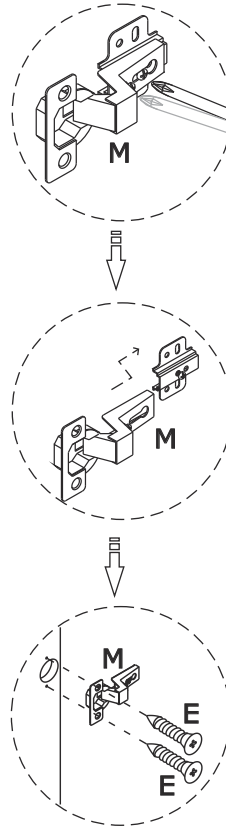
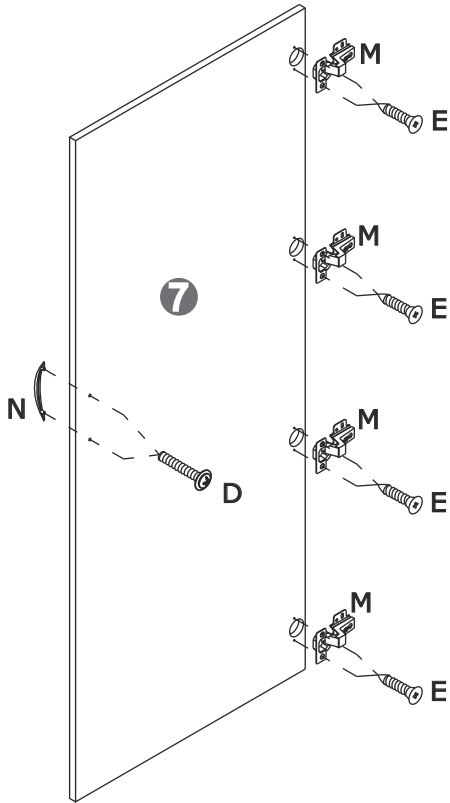

48

<b>Ex20</b>  3.5X14mm	<b>Kx4</b> 	
--	---	---

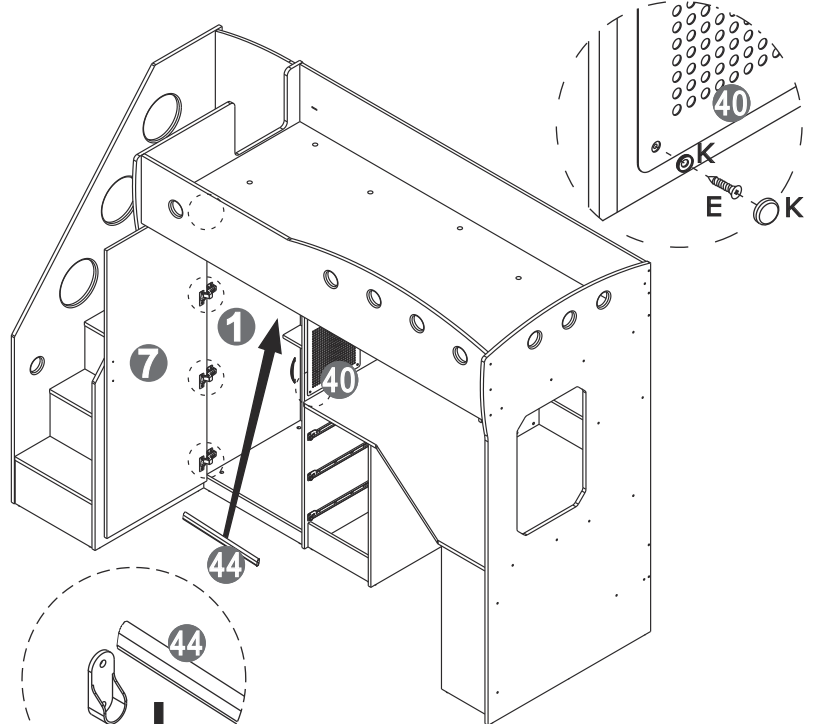
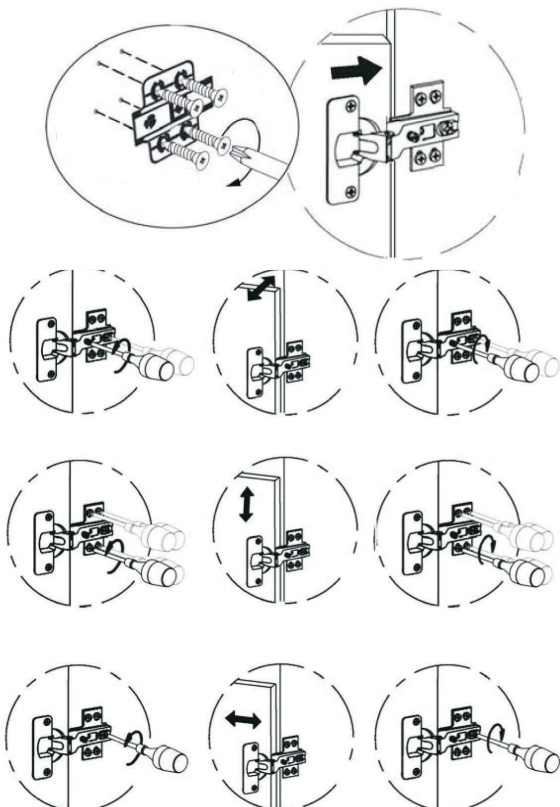

49

Hx12



M6X25mm

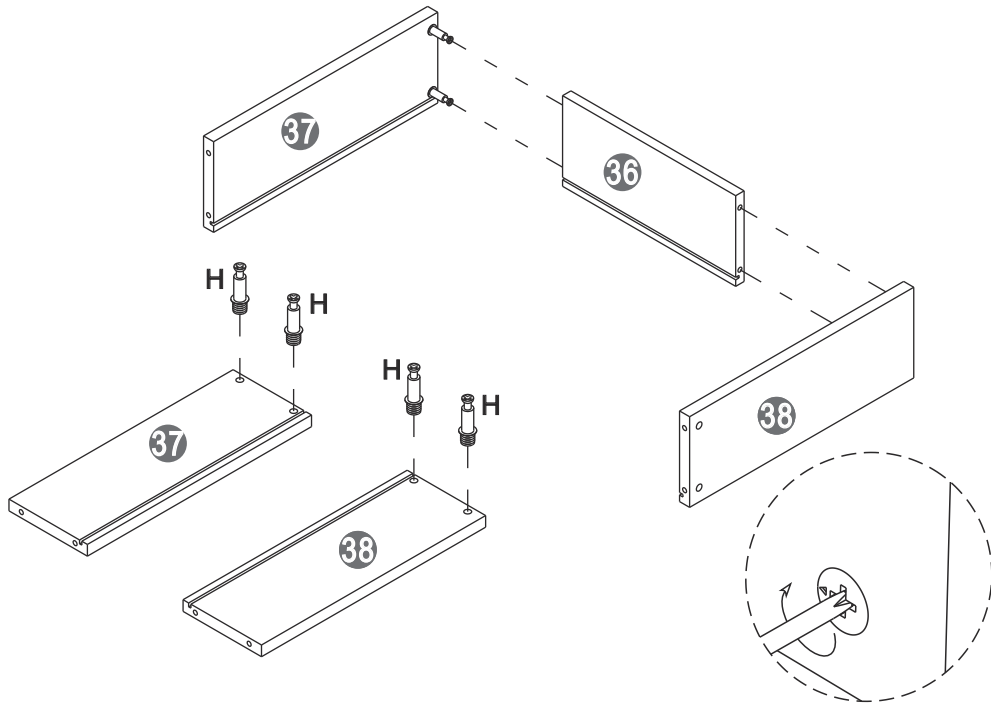
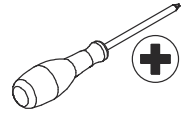

X3

50

Cx6



M4X21mm

Hx12



M6X25mm

Nx3

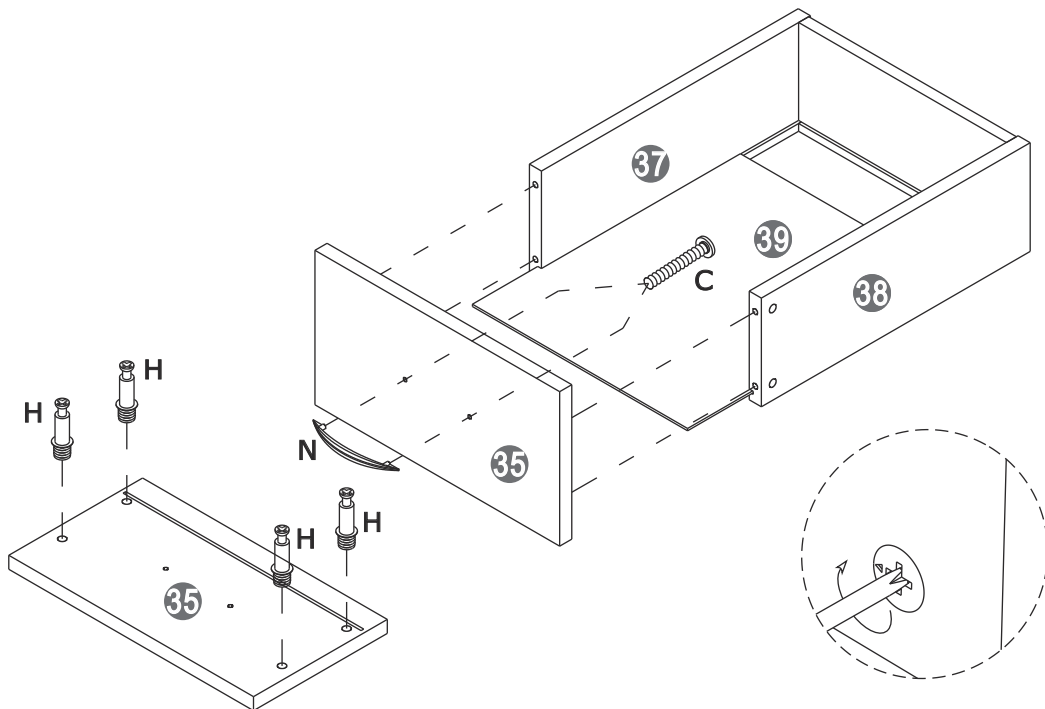
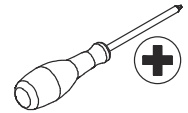

X3

51

Ex18



3.5X14mm

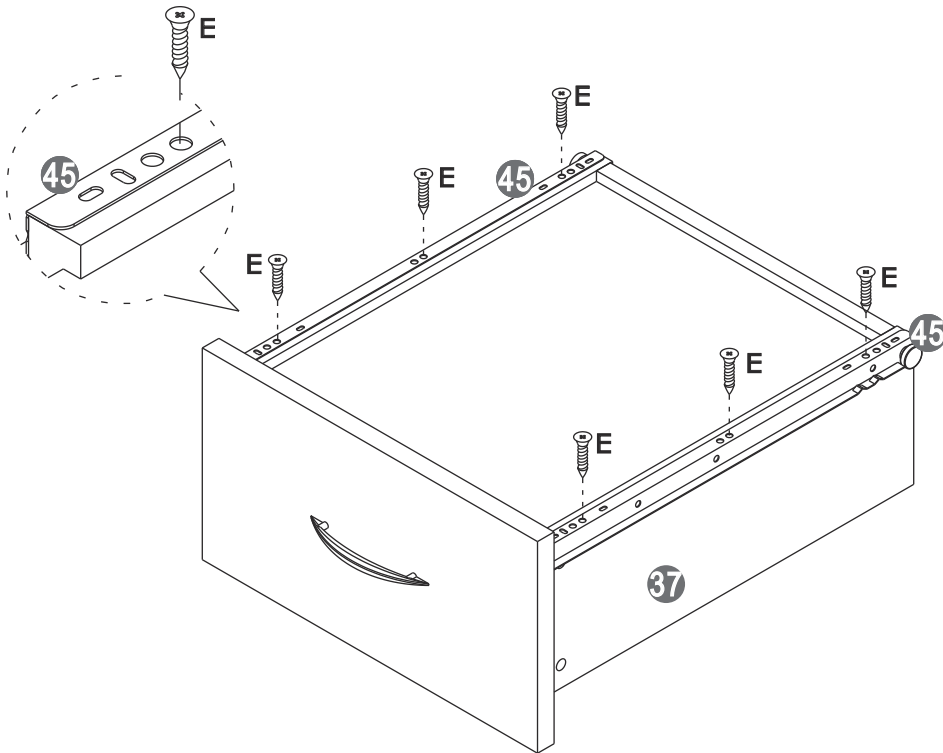
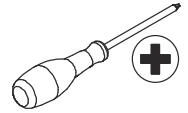

X3

52

Qx46

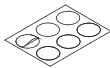

Ø21mm

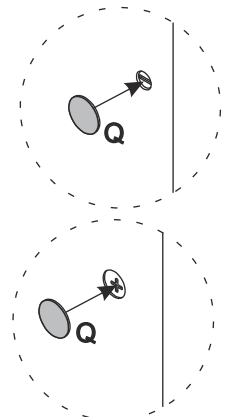
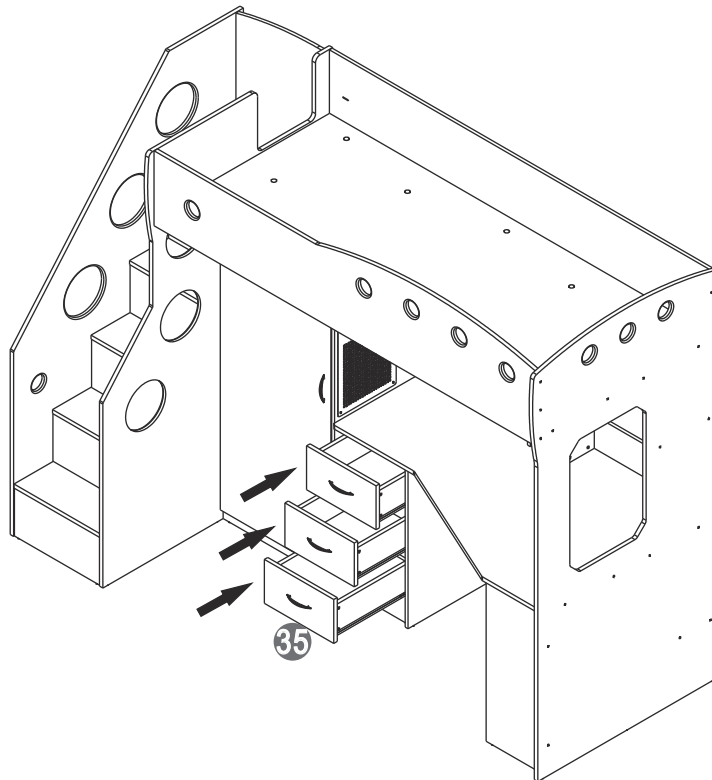

43/45

53

Bx2



M6X10mm

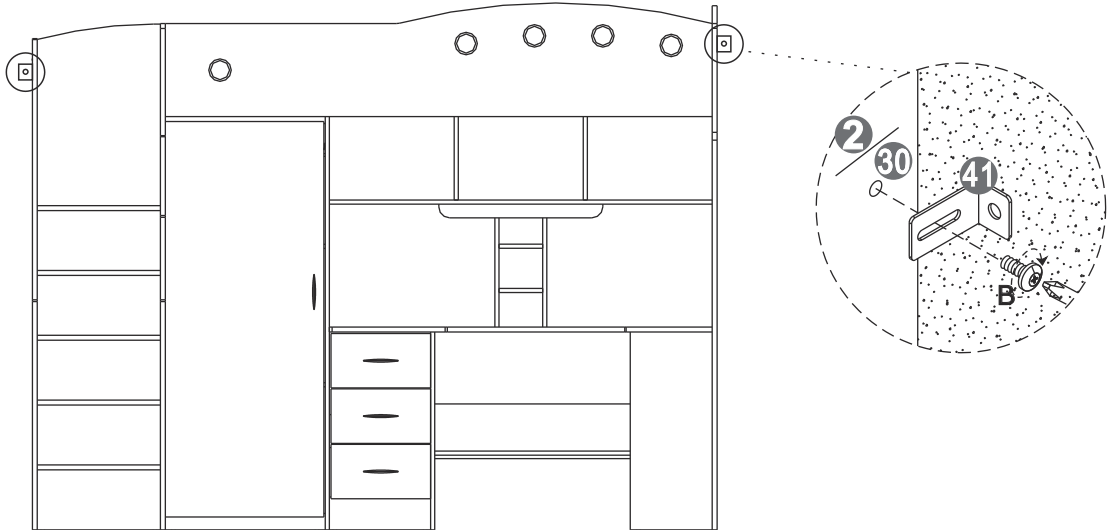
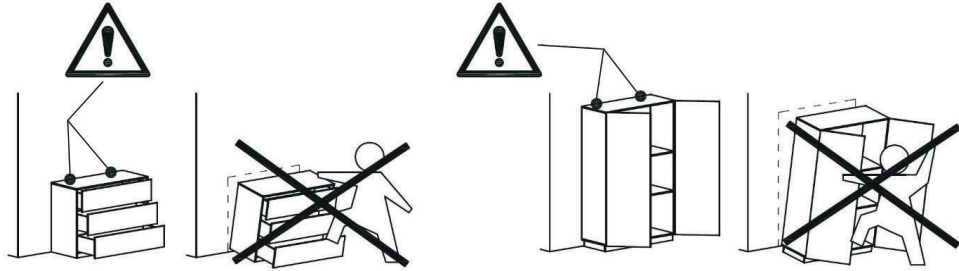
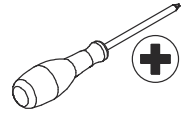

54

