

# FANDRUP

132712

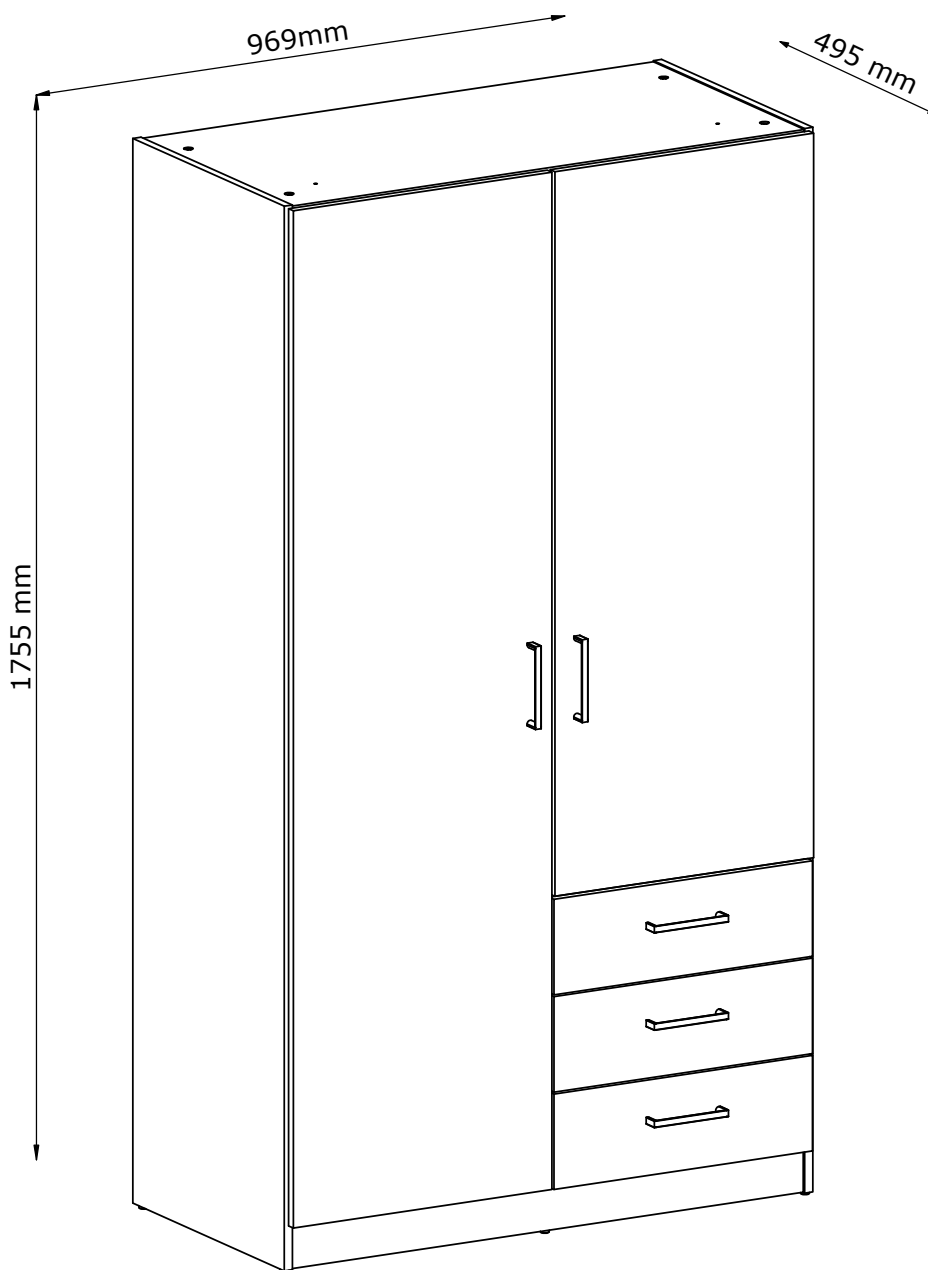

**FR**  
Pensez à  
donner ou recycler.



OU



OU



<https://quefairedemesdechets.fr>

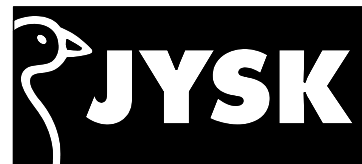

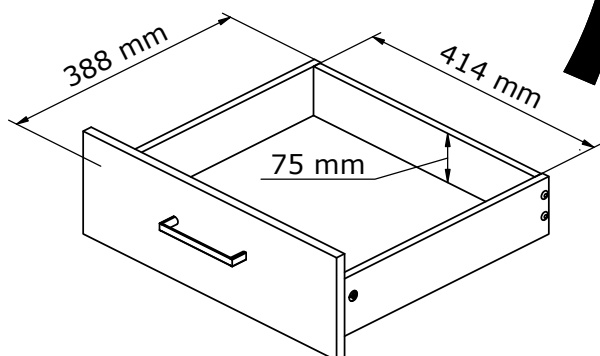
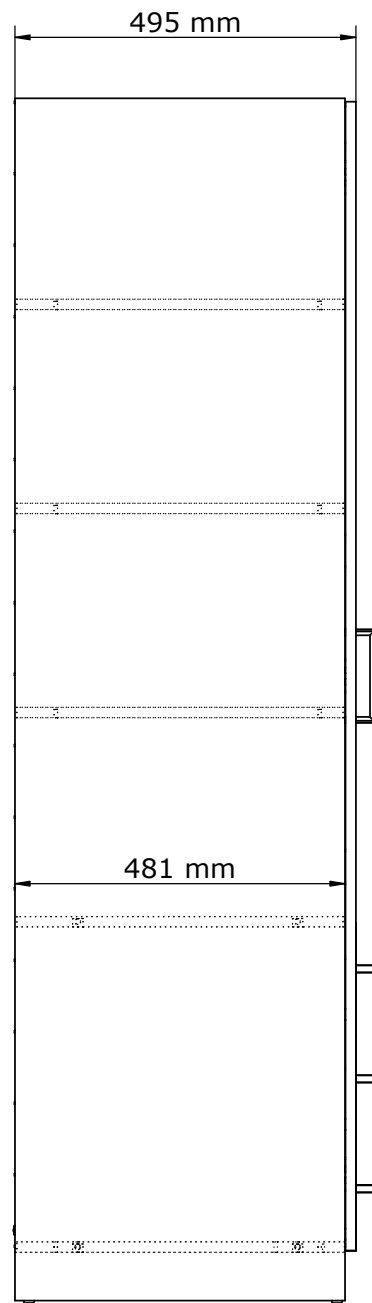
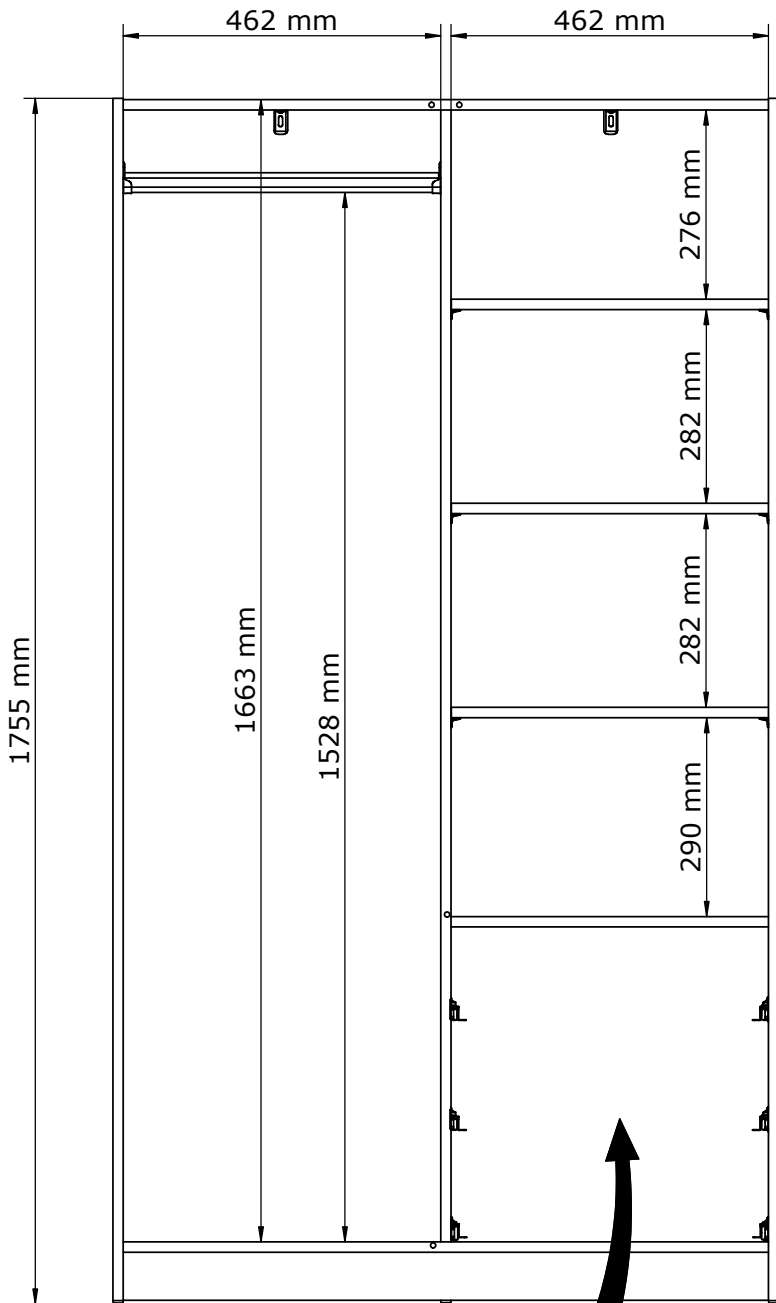
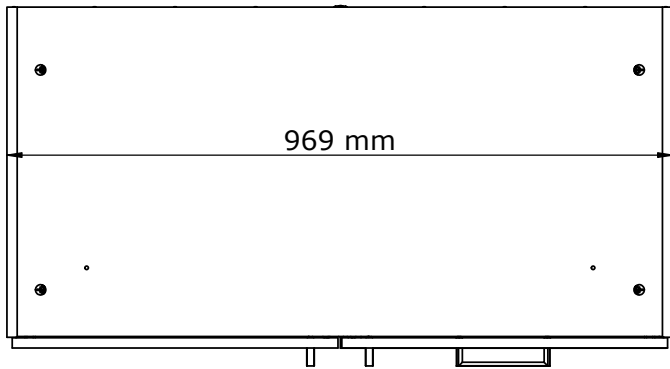

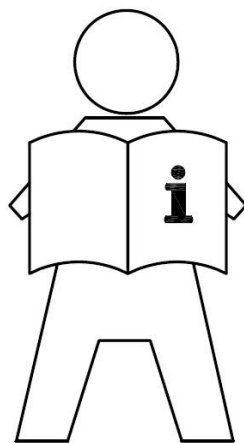

**EN: IMPORTANT INFORMATION!**

*Please read the entire manual carefully before starting to assemble and/or using this product. Follow the manual thoroughly and keep it for further reference.*

**FR: INFORMATIONS IMPORTANTES**

*Veillez lire attentivement l'ensemble du manuel avant de commencer à monter et/ou utiliser ce produit. Suivez rigoureusement le manuel et conservez-le pour toute consultation ultérieure.*

**LV: SVARĪGA INFORMĀCIJA!**

*Pirms šī izstrādājuma montāžas un/vai lietošanas uzsākšanas pilnībā izlasiet lietošanas pamācību. Stingri ievērojiet pamācības norādījumus un saglabājiet to turpmākai lietošanai.*

**LT: SVARBI INFORMACIJA!**

*Prieš pradėdami montuoti gaminį ir (arba) juo naudotis, prašome atidžiai perskaityti visą vadovą. Atidžiai skaitykite vadovą ir turėkite jį su savimi, kad galėtumėte toliau vadovautis jo nuorodomis.*

**EE: OLULINE TEAVE!**

*Enne kui alustate toote kokku panemist ja/või kasutamist, lugege see kasutusjuhend hoolikalt läbi. Järgige täpselt juhendis toodud juhiseid ja hoidke juhend alles.*

**RU: ВАЖНАЯ ИНФОРМАЦИЯ!**

*Внимательно и полностью прочитайте это руководство, прежде чем приступать к сборке или использованию этого изделия. Следуйте всем инструкциям этого руководства и сохраните его на будущее для справки.*



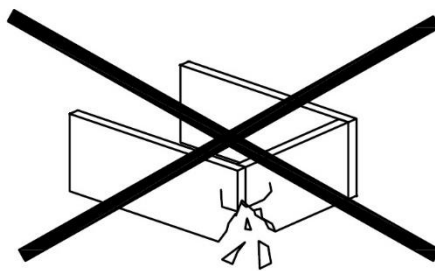

**EN: WARNING TO AVOID SCRATCHES!**

*In order to avoid scratching this furniture should be assembled on a soft layer - could be a rug.*

**FR: AVERTISSEMENT POUR ÉVITER LES RAYURES**

*Afin d'éviter les rayures, ce meuble doit être monté sur une surface souple (un tapis, par exemple).*

**LV: BRĪDINĀJUMS PAR SKRĀPĒJUMIEM!**

*Lai nesaskrāpētu šo izstrādājumu, veiciet montāžu uz mīkstas pamatnes, piemēram, paklāja.*

**LT: ĮSPĖJIMAS, KAD IŠVENGTUMĖTE ĮBRĖŽIMŲ!**

*Šio baldų nesubraižysite, jei jį surinksite ant švelnaus paviršiaus, pavyzdžiui, kilimo.*

**EE: HOIATUS KRIIMUSTUSTE VÄLTIMISEKS!**

*Kriimustuste tekkimise vältimiseks mööblile tuleb see kokku panna pehmel pinnal, nt kaltsuvaibal.*

**RU: ПРЕДУПРЕЖДЕНИЕ ОТНОСИТЕЛЬНО ЦАРАПИН!**

*Во избежание нанесения царапин, сборку этой мебели необходимо выполнять на мягкой поверхности, например на ковре.*



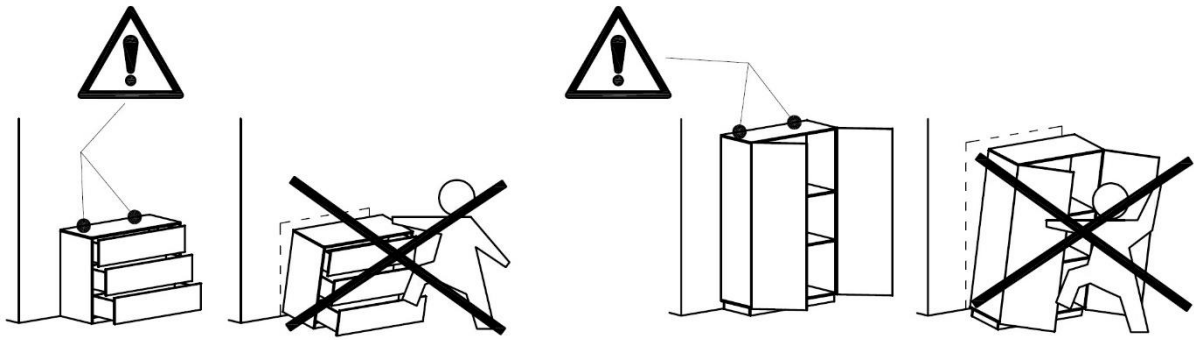

**EN: ANTI-TOPPLE WARNING!**

*This product has to be permanently fixed to the wall with the bracket(s) included, to avoid fatal injury in case it topples over. The pack only contains screws for fastening the anti-topple bracket(s) itself to the product. Please contact your DIY or hardware store for advice on the correct type of screws/raw plugs for your type of wall.*

**FR: AVERTISSEMENT ANTIBASCULEMENT**

*Ce produit doit être fixé de manière permanente au mur à l'aide du/des support(s) inclus afin d'éviter des blessures mortelles en cas de basculement. L'emballage contient des vis pour attacher le(s) support(s) antibasculement au produit. Veuillez contacter votre magasin de bricolage ou votre quincaillerie pour obtenir des conseils sur le type de vis/chevilles adapté à votre mur.*

**LV: BRĪDINĀJUMS PAR APGĀŠANOS!**

*Šis produkts ir jāpiestiprina pie sienas ar komplektā iekļauto(-ajiem) kronšteinu(-iem), lai novērstu nāvējošu savainojumu risku, tam apgāžoties. Iepakojumā ir skrūves tikai pretapgāšanās kronšteina(-u) piestiprināšanai pie produkta. Informāciju par to, kādas skrūves piemērotas Jūsu sienai, jautājiet saimniecības preču vai būvizstrādājumu veikalā.*

**LT: ĮSPĖJIMAS DĖL NUVERTIMO!**

*Šį gaminį būtina tinkamai pritvirtinti prie sienos naudojant pridėtas gembes, kad išvengtumėte mirtino sužalojimo jam nuvirtus. Pakuotėje yra tik varžtai gembėms prie gaminio pritvirtinti. Užeikite į artimiausią statybinių prekių parduotuvę ir paprašykite savo sienai tinkamiausių varžtų (kaiščių).*

**EE: ÜMBERKUKKUMISOHT!**

*Toote ümberkukkumisest tuleneda võiva eluohtliku õnnetuse vältimiseks tuleb see kinnitada komplekti kuuluva(te) kronsteini(de) abil püsivalt seina külge. Komplekti kuuluvad ainult kruvid, mis on mõeldud ümberkukkumist takistava(te) kronsteini(de) kinnitamiseks toote külge. Soovituste saamiseks sobivate kruvide/tüüblite leidmiseks oma seina jaoks, konsulteeri DIY esindaja või rauakaupade kaupluse müüjaga.*

**RU: ПРЕДУПРЕЖДЕНИЕ ОБ ОПРОКИДЫВАНИИ!**

*Во избежание опрокидывания это изделие должно быть надежно прикреплено к стене с помощью прилагаемых кронштейнов. В комплект входят винты только для прикрепления кронштейнов к самому изделию. Шурупы и дюбели для крепления к стене конкретного типа можно найти в строительном или хозяйственном магазине.*

**EN: IMPORTANT!**

*It is important that any product which is assembled using any kind of screw is re-tightened 2 weeks after assembly, and once every 3 months - in order to assure stability through-out the lifespan of the product.*

**FR: IMPORTANT**

*Il est important que tout produit monté à l'aide de vis soit resserré 2 semaines après son montage, puis tous les 3 mois, afin de garantir sa stabilité durant tout son cycle de vie.*

**LV: SVARĪGI!**

*Ir svarīgi, lai jebkuram produktam, kas tiek uzstādīts ar jebkādu skrūvju palīdzību, skrūves tiktu atkārtoti pievilktas 2 nedēļas pēc montāžas, pēc tam – reizi 3 mēnešos, tā nodrošinot stabilitāti visā izstrādājuma kalpošanas laikā.*

**LT: SVARBU!**

*Bet kokį varžtais tvirtinamą gaminį 2 savaites po surinkimo bei kas 3 mėnesius reikia papildomai suveržti – taip užtikrinamas naudojamo gaminio stabilumas.*

**EE: TÄHTIS!**

*Oluline on, et toote kruvisid pingutataks 2 nädalat pärast kokkupanekut ja seejärel iga 3 kuu järel, et tagada stabiilsus kogu toote eluea jooksul.*

**RU: ВАЖНО!**

*В любом изделии, собранном с использованием винтов любого типа, необходимо через 2 недели после сборки и в дальнейшем каждые 3 месяца подтягивать винты, чтобы обеспечить прочность изделия в течение срока эксплуатации.*





**EN: GENERAL INSTRUCTION FOR FURNITURE WITH FABRIC!**

*Wipe clean with a damp cloth. Use only clean water.*

*Dust and dirt can be vacuum cleaned or wiped with a clean soft cloth.*

*Do not use detergents, solvents or other chemicals on fabric as this may cause discoloration.*

*However, certain removable fabrics may be washed, but in such cases there will ALWAYS be a washing instruction on the fabric.*

**FR: INSTRUCTIONS GÉNÉRALES POUR LE MOBILIER EN TISSU!**

*Nettoyez à l'aide d'un chiffon humide. N'utilisez que de l'eau claire.*

*La poussière et la saleté peuvent être aspirées ou essuyées à l'aide d'un chiffon doux et propre.*

*N'utilisez aucun détergent, solvant ou autre produit chimique sur le tissu, car ceci pourrait le décolorer.*

*Cependant, certains tissus amovibles peuvent être lavés, mais dans ce cas le tissu comportera TOUJOURS des instructions de lavage.*

**LV: VISPĀRĪGI KOPŠANAS NORĀDĪJUMI MĒBELĒM AR AUDUMU!**

*Noslaukiet ar mitru drānu. Izmantojiet tikai tīru ūdeni.*

*Putekļus un netīrumus var notīrīt ar putekļusūcēju vai noslaucīt ar mīkstu drānu.*

*Auduma tīrīšanai neizmantojiet mazgāšanas līdzekļus, šķīdinātājus vai citas ķīmikālijas, jo auduma krāsa var izbalēt.*

*Atsevišķus noņemamos audumus var mazgāt, taču tad uz auduma VIENMĒR būs sniegti kopšanas norādījumi.*

**LT: BENDROSIOS INSTRUKCIJOS BALDAMS PADENGTIEMS AUDINIUI!**

*Švariai nušluostykite drėgna šluoste. Naudokite tik švarų vandenį.*

*Dulkės ir nešvarumai gali būti susiurbti arba nuvalyti švaria, minkšta šluoste.*

*Nenaudokite detergentų, tirpiklių ar kitų chemikalų audiniams, nes šie gali sukelti spalvos išblukimą.*

*Visgi, kai kurie nuimami audiniai gali būti skalbiami, bet tokiais atvejais ant audinio etiketės VISADA turi būti pateiktos skalbimo instrukcijos.*

**EE: ÜLDISED JUHISED KANGAGA MÖÖBLI JAOKS!**

*Puhastage niiske lapiga. Kasutage ainult puhast vett.*

*Tolmu ja mustust saab eemaldada tolmuimejaga või ära pühkida puhta pehme lapiga.*

*Ärge kasutage kangal pesuvahendeid, lahusteid või muid kemikaale, kuna see võib põhjustada värvimuutusi.*

*Küll aga võib teatud eemaldatavaid kangaid pesta, kuid sellisel juhul on kanga küljes ALATI pesujuhend.*

**RU: ОБЩИЕ УКАЗАНИЯ ПО УХОДУ ЗА МЕБЕЛЬЮ С ОТДЕЛКОЙ ИЗ ТКАНИ!**

*Очистите изделие чистой влажной тряпкой. Используйте только чистую воду.*

*Пыль и грязь можно удалять пылесосом или чистой мягкой тряпкой.*

*Не наносите моющие средства, растворители или другие химические вещества на ткань, поскольку они могут привести к вымыванию цвета.*

*Некоторые съемные элементы из ткани можно стирать. В таких случаях к ткани ОБЯЗАТЕЛЬНО прилагается инструкция по стирке.*

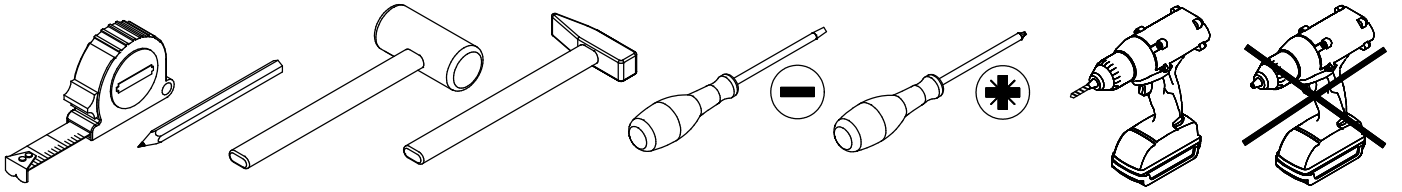

0110405 x 7

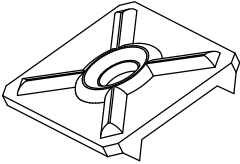

19x14x3 mm

0110621 x 2

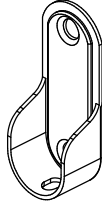

18x45,5x12 mm

0111042 x 12

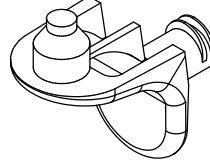

21x19,3x12 mm

0113451 x 2

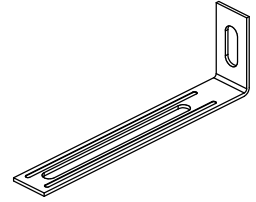

31x101x15x1,3 mm

0113453 x 1

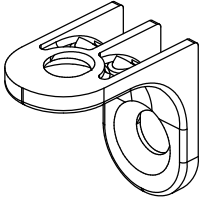

18x18x11 mm

0120203 x 26

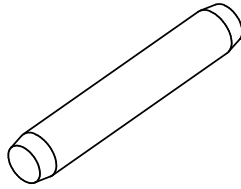

Ø5x30 mm

0120228 x 12

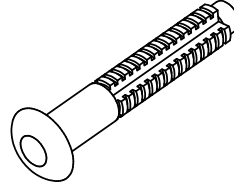

Ø6,3x40 mm

0123006 x 46

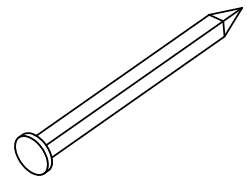

1,4x25 mm

0125215 x 12

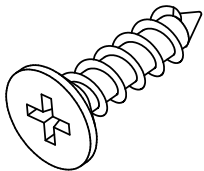

Ø3x12 mm

0125233 x 6

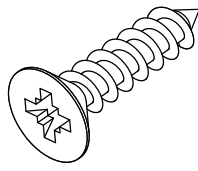

Ø3,5x15 mm

0125440 x 4

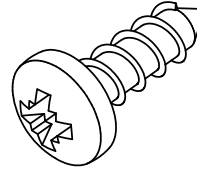

Ø4x13 mm

0125502 x 7

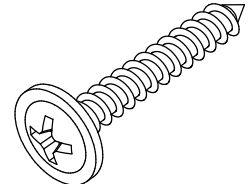

Ø3x20 mm

0125506 x 10

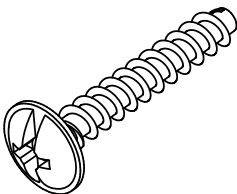

Ø4x25 mm

0126007 x 2

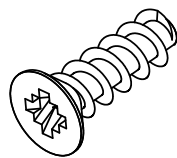

Ø4,2x13 mm

0126040 x 16

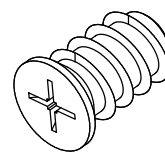

Ø6,3x10,5 mm

0131513 x 22

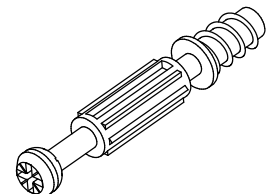

Ø7,5x44 mm

0131687 x 22

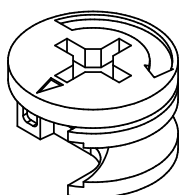

Ø15x9,5 mm

0141655 x 3

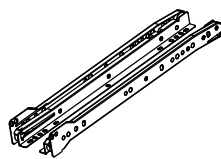

L=350 mm

0152500 x 6

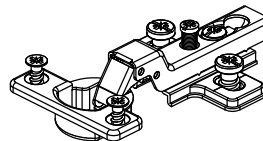

Ø26 mm, FK8

0163015 x 5

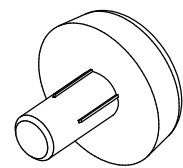

Ø15x4,8 mm

0198202 x 1

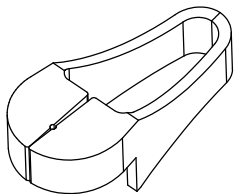

45x20x16 mm

0196203 x 4

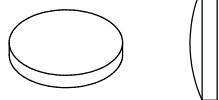

Ø7x1,5 mm

0180605 x 5

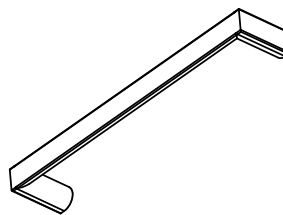

136x26x11 mm

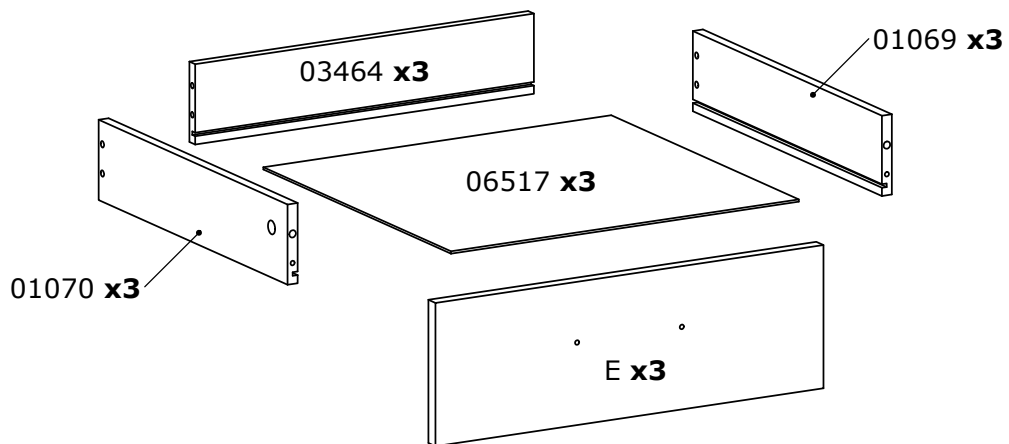
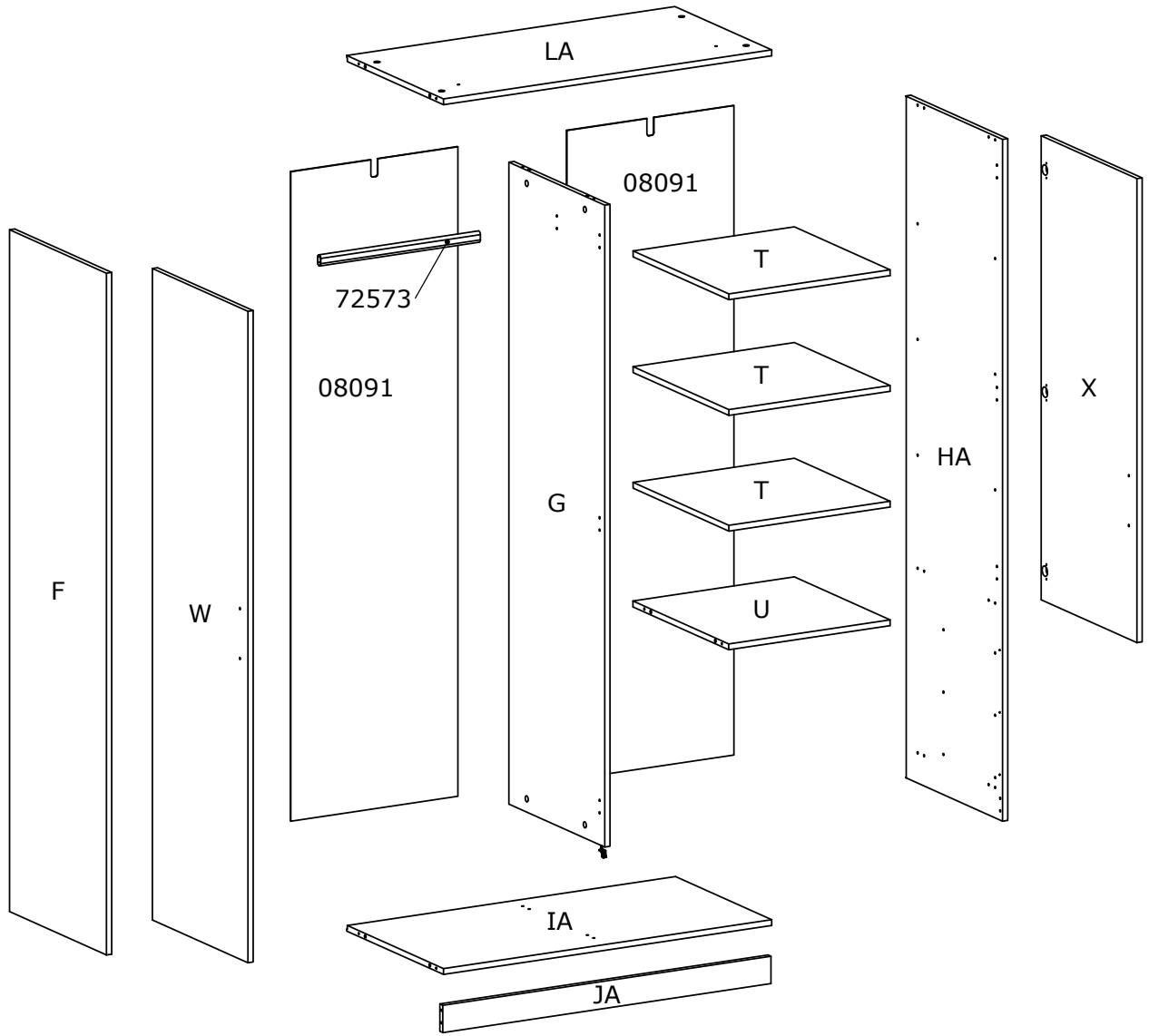

**Box 1/2:**

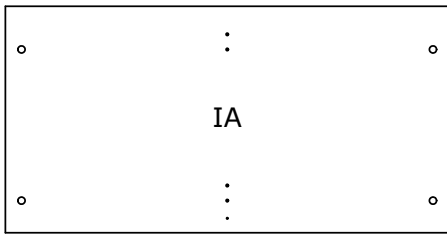

939x479,5x15mm

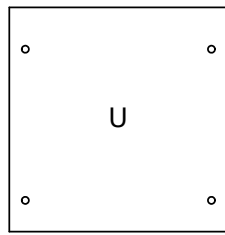

462x474,5x15mm

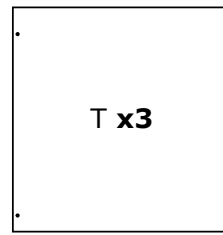

461,5x474,5x15mm

**03464 x3**  
414x88x12,2mm

**01069 x3**  
400x88x12,2mm

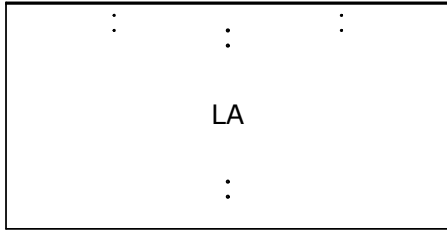

939x479,5x15mm

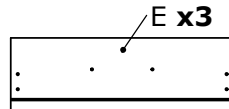

472x157x12mm

**01070 x3**  
400x88x12,2mm

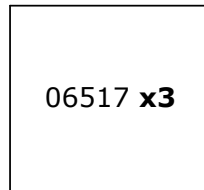

425x397x2,5mm

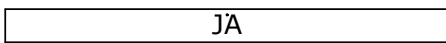

939x70x15mm

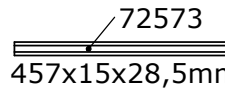

457x15x28,5mm

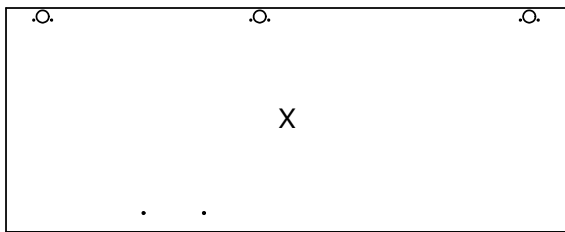

1191x474x15mm

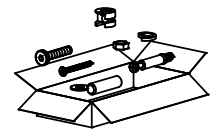

**Box 2/2:**

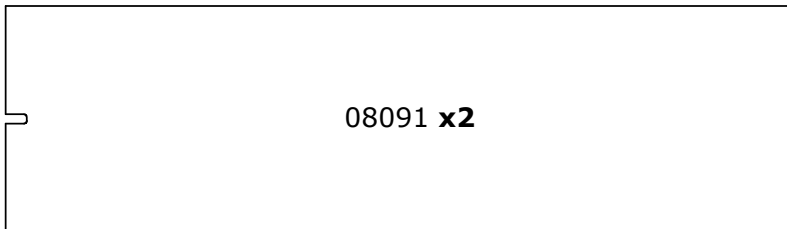

1667x478x2,5mm



1647,5x475,5x15mm

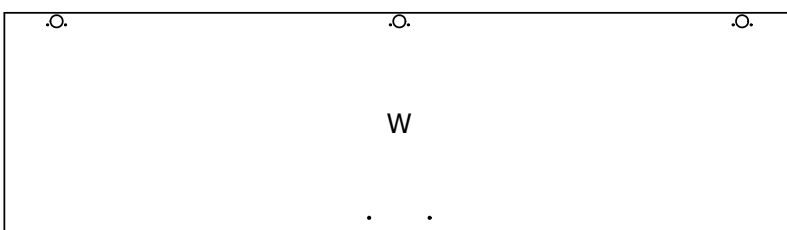

1672x474x15mm

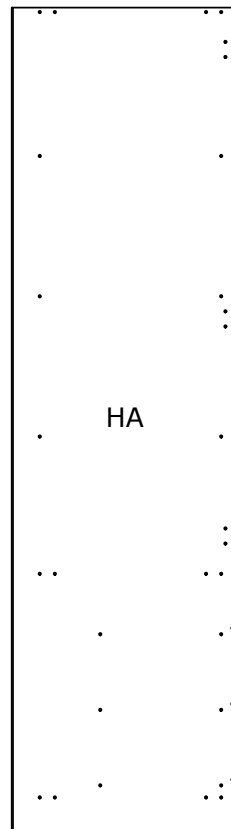

1750x480,5x15mm

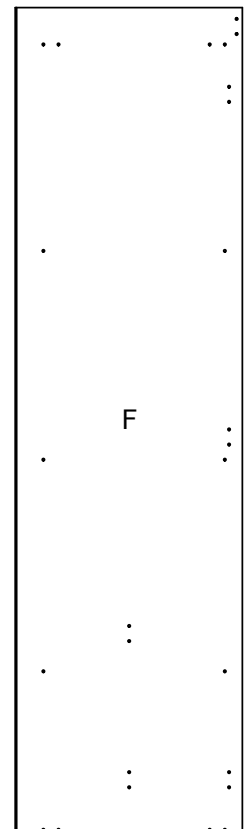

1750x480,5x15mm

1

0120203 x 4  Ø5x30 mm	
--	---

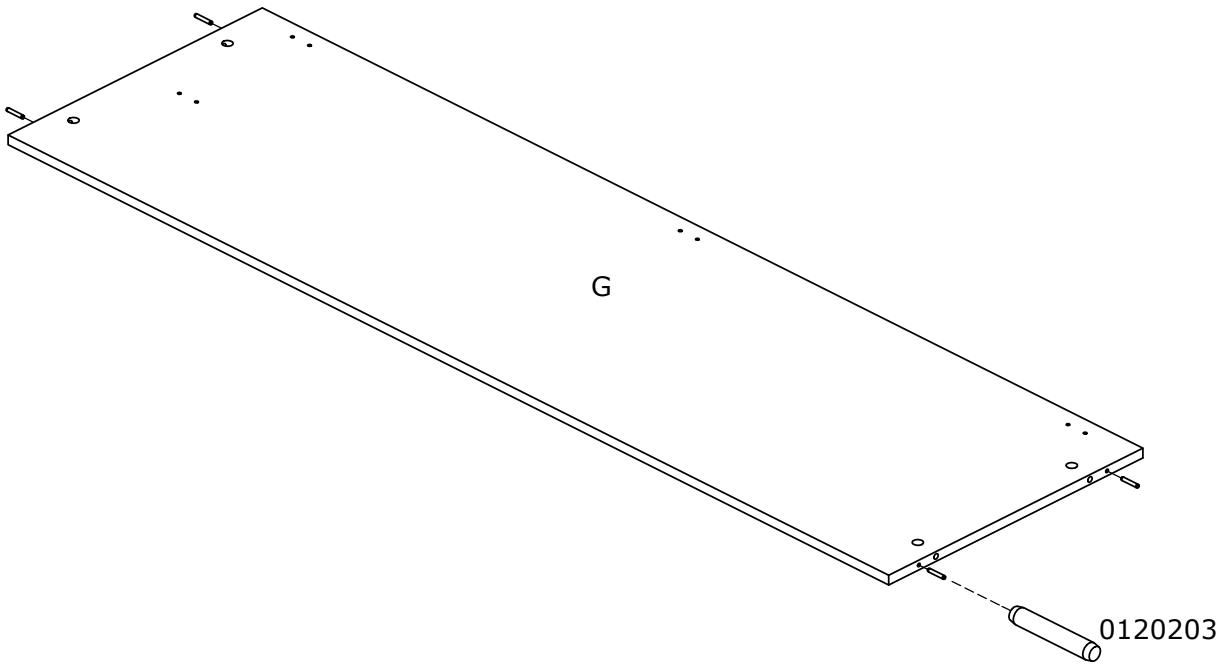

2

0110621 x 1  18x45,5x12 mm	0126040 x 2  Ø6,3x10,5 mm	
---	--	---

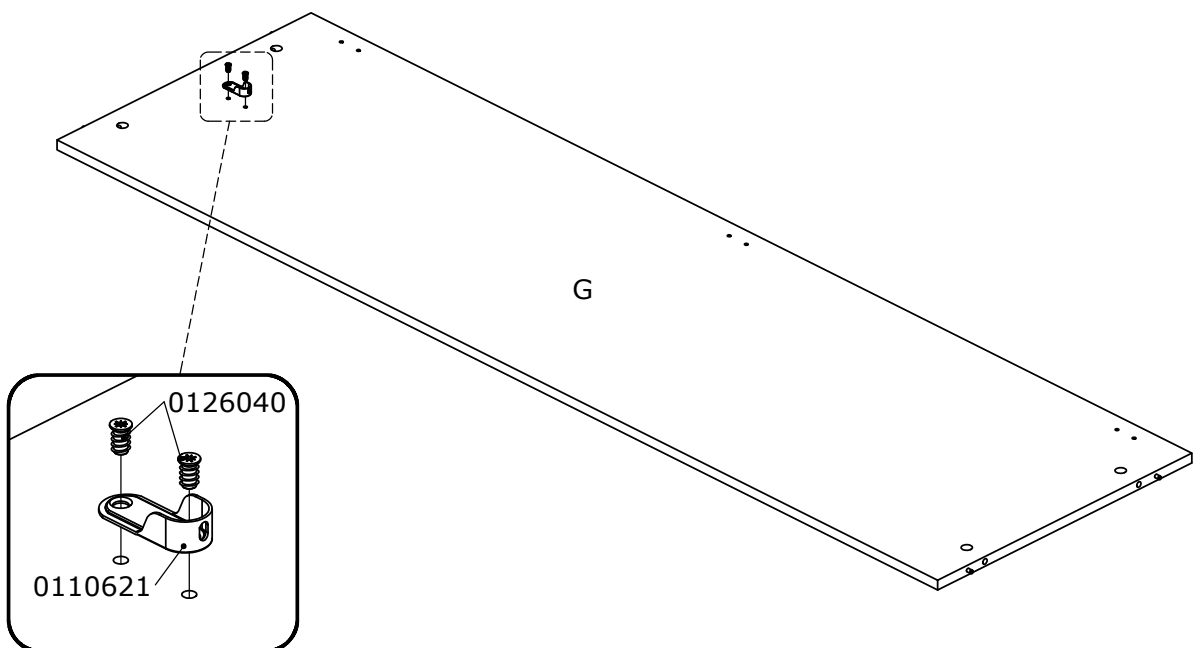

3

0141655 x 3

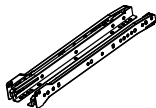

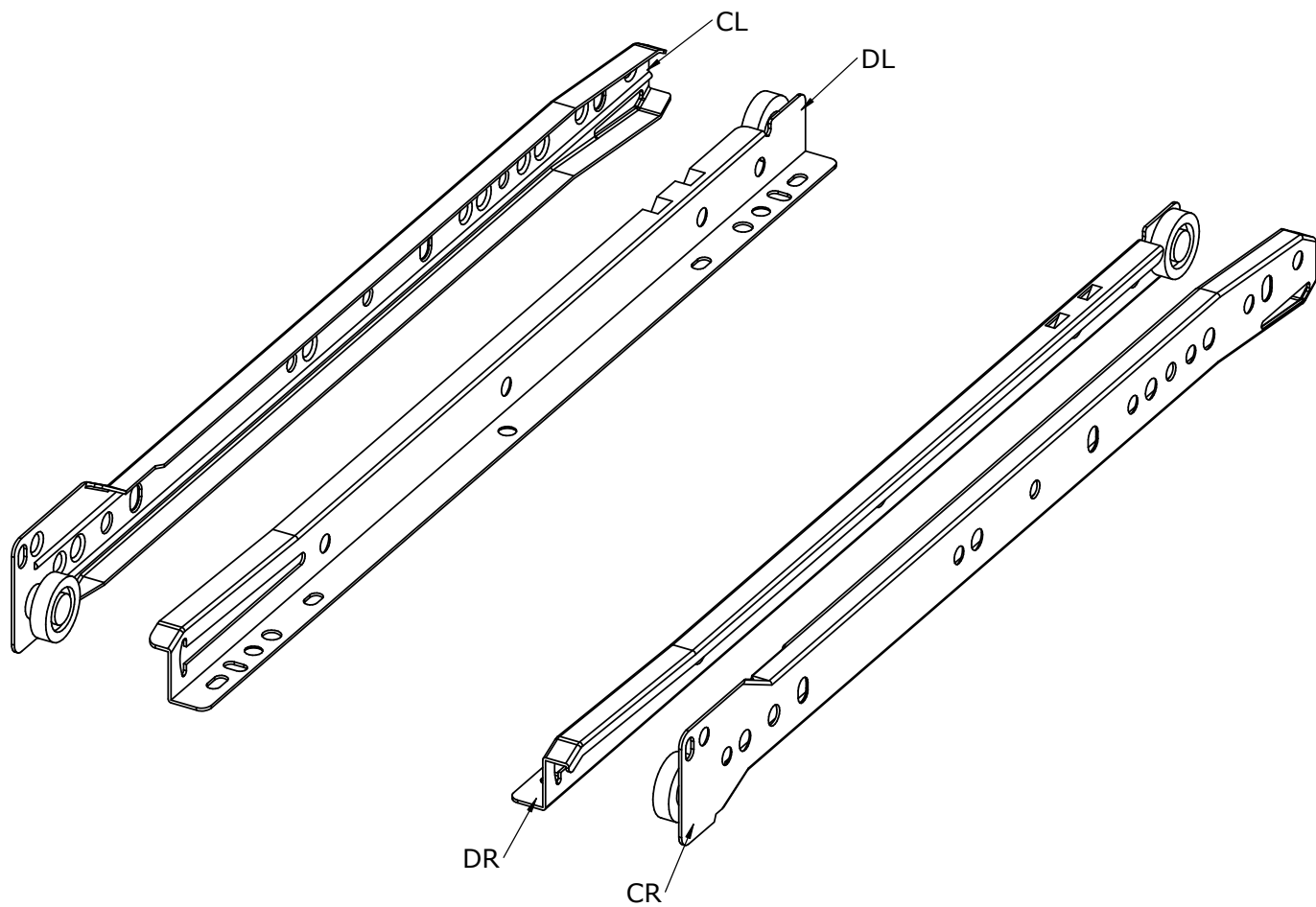

L=350 mm

# 0141655

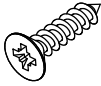

4

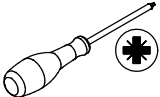
0125233 x 3  Ø3,5x15 mm	0126040 x 6  Ø6,3x10,5 mm	0141655 x 3  L=350 mm	
--	--	--	---

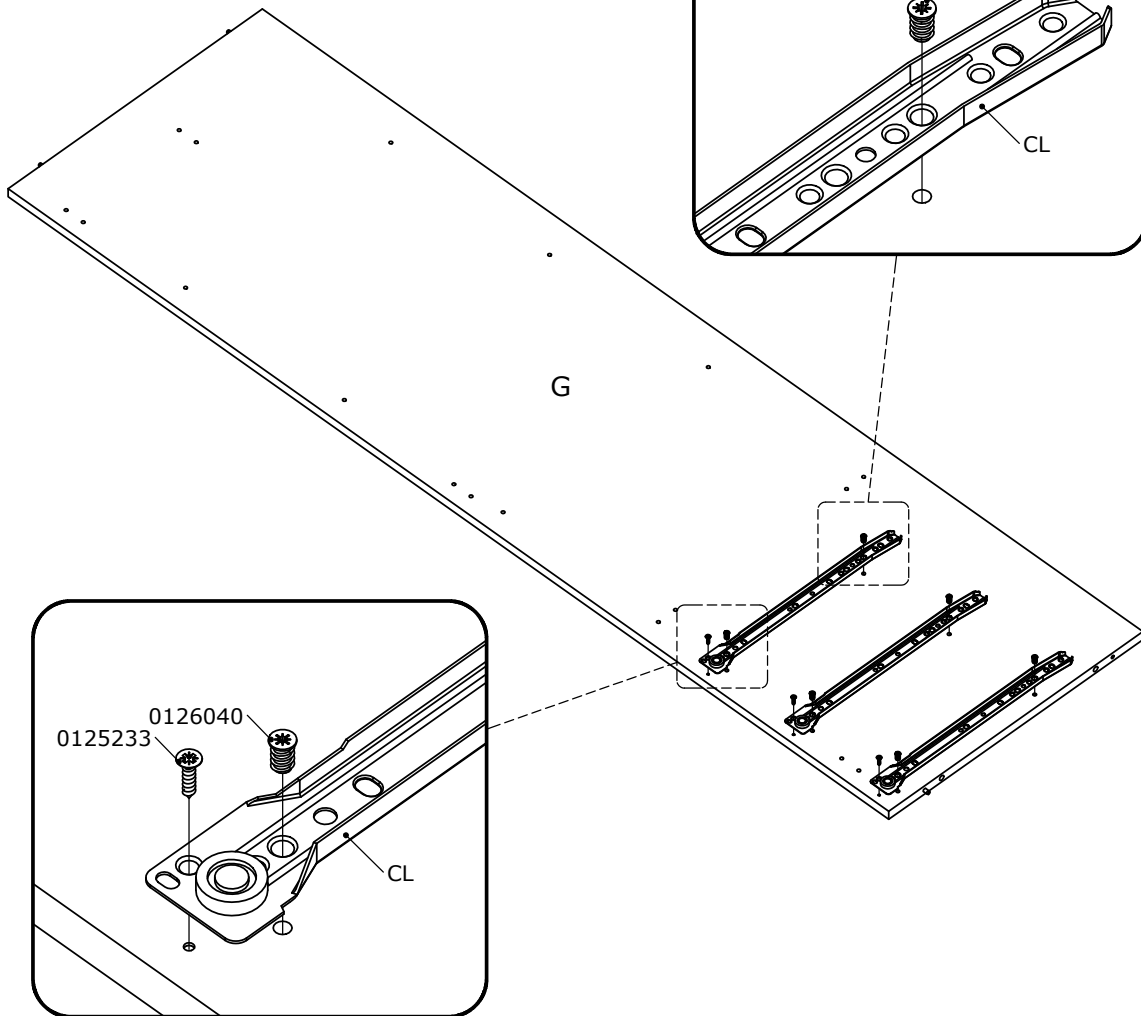
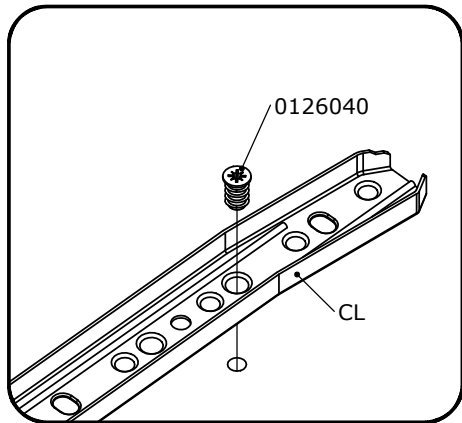
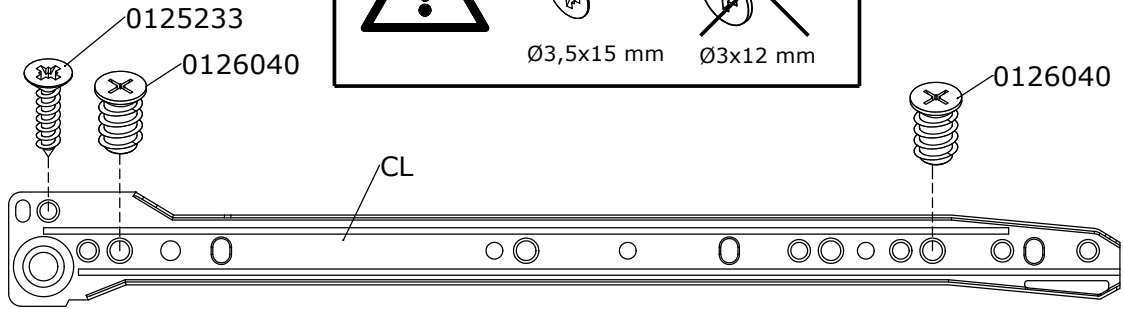
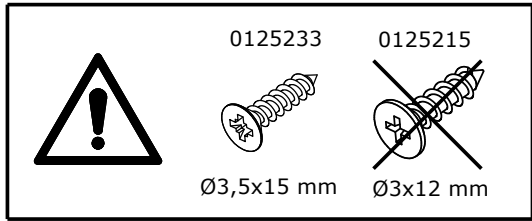

5

0131513 x 2

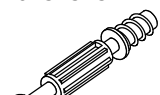

Ø7,5x44 mm

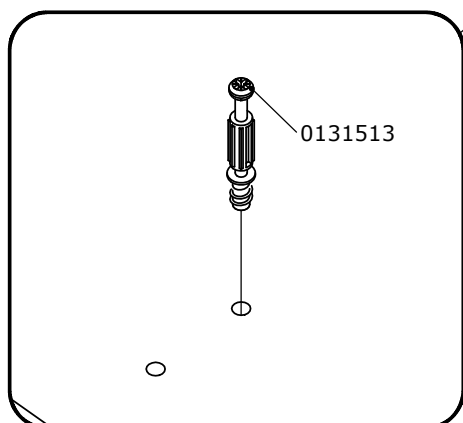
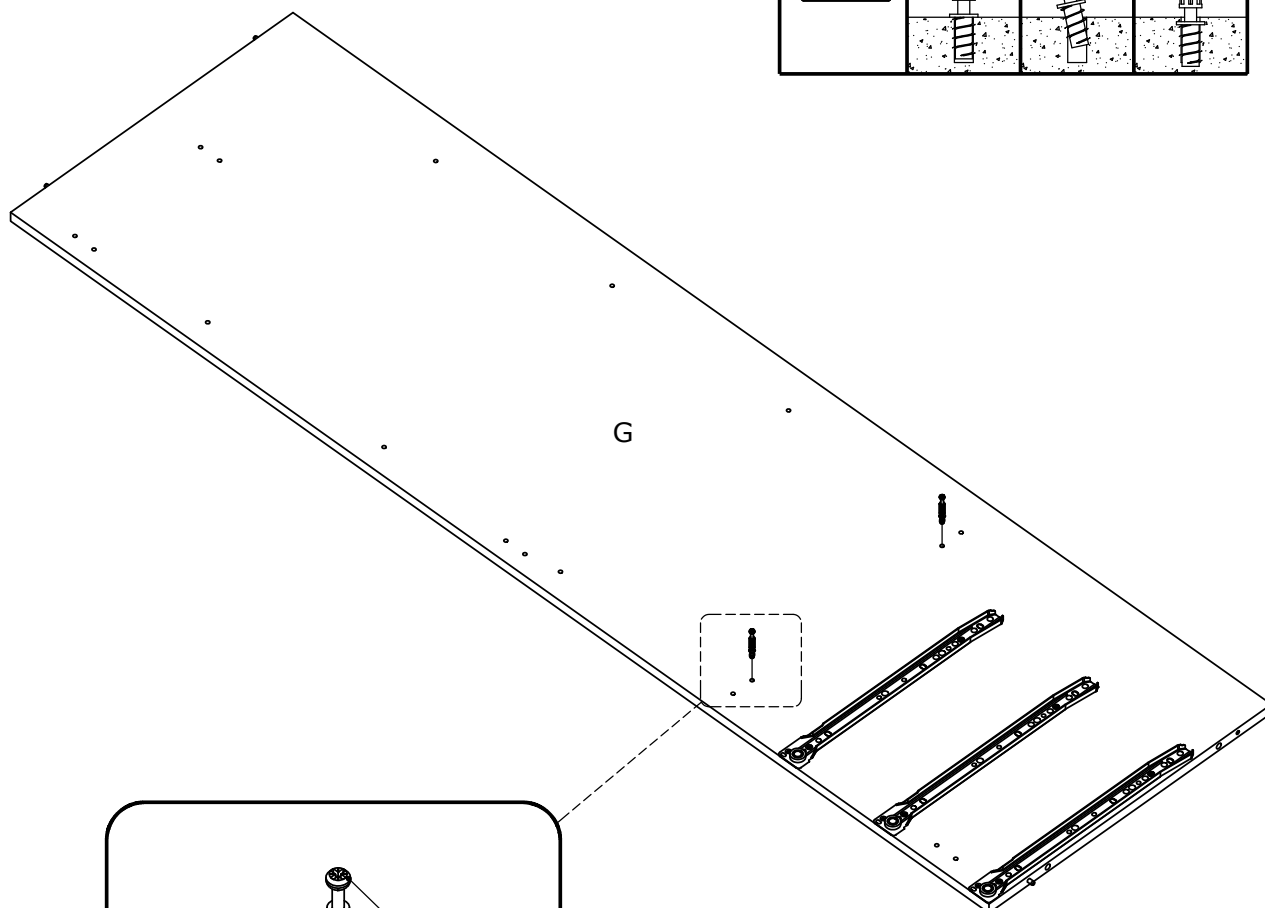
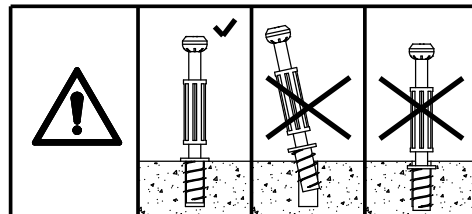
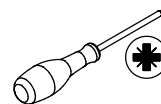

6

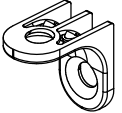
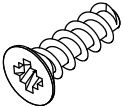
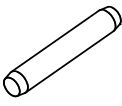
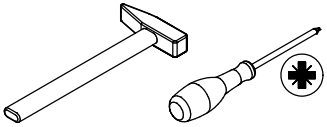
0113453 x 1  18x18x11 mm	0126007 x 1  Ø4,2x13 mm	0120203 x 8  Ø5x30 mm	
---	--	--	---

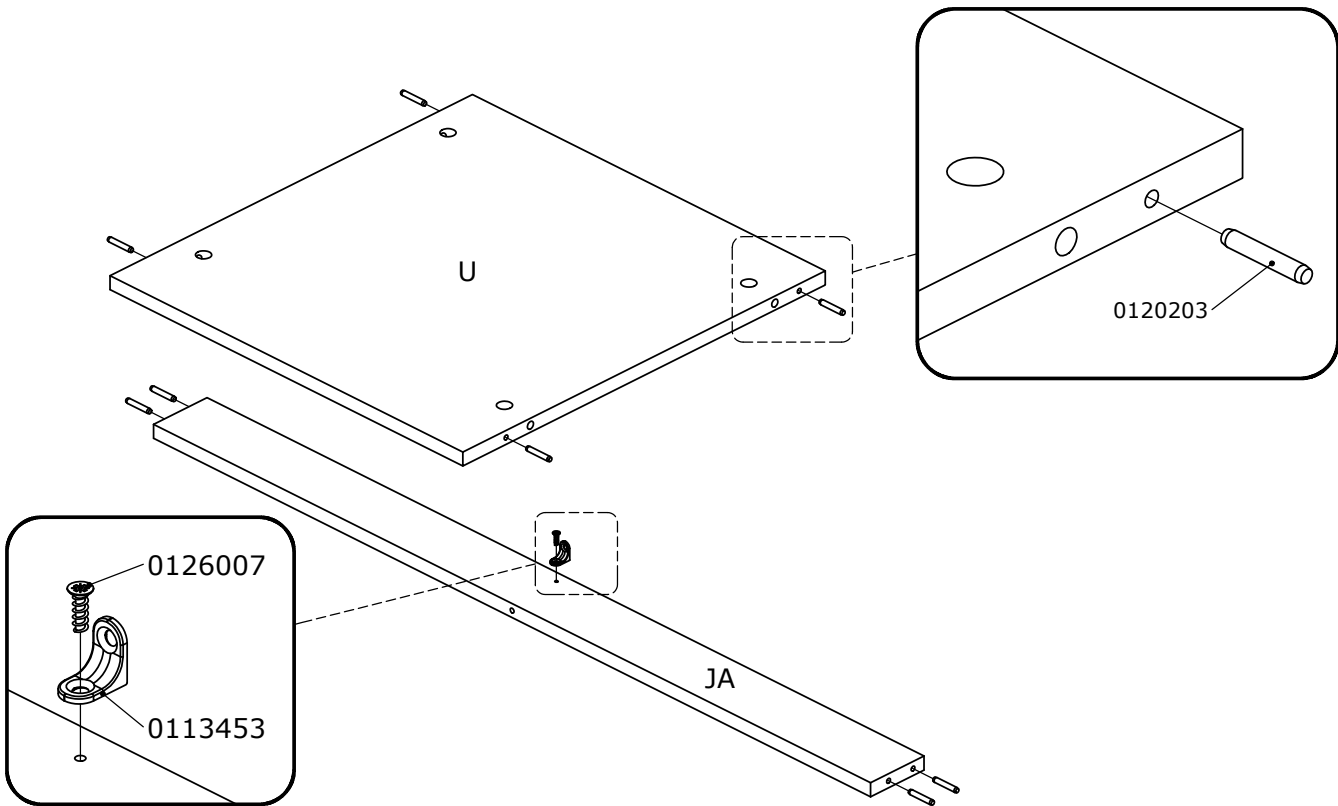

7

0120203 x 8  Ø5x30 mm	0131513 x 4  Ø7,5x44 mm	
--	--	---

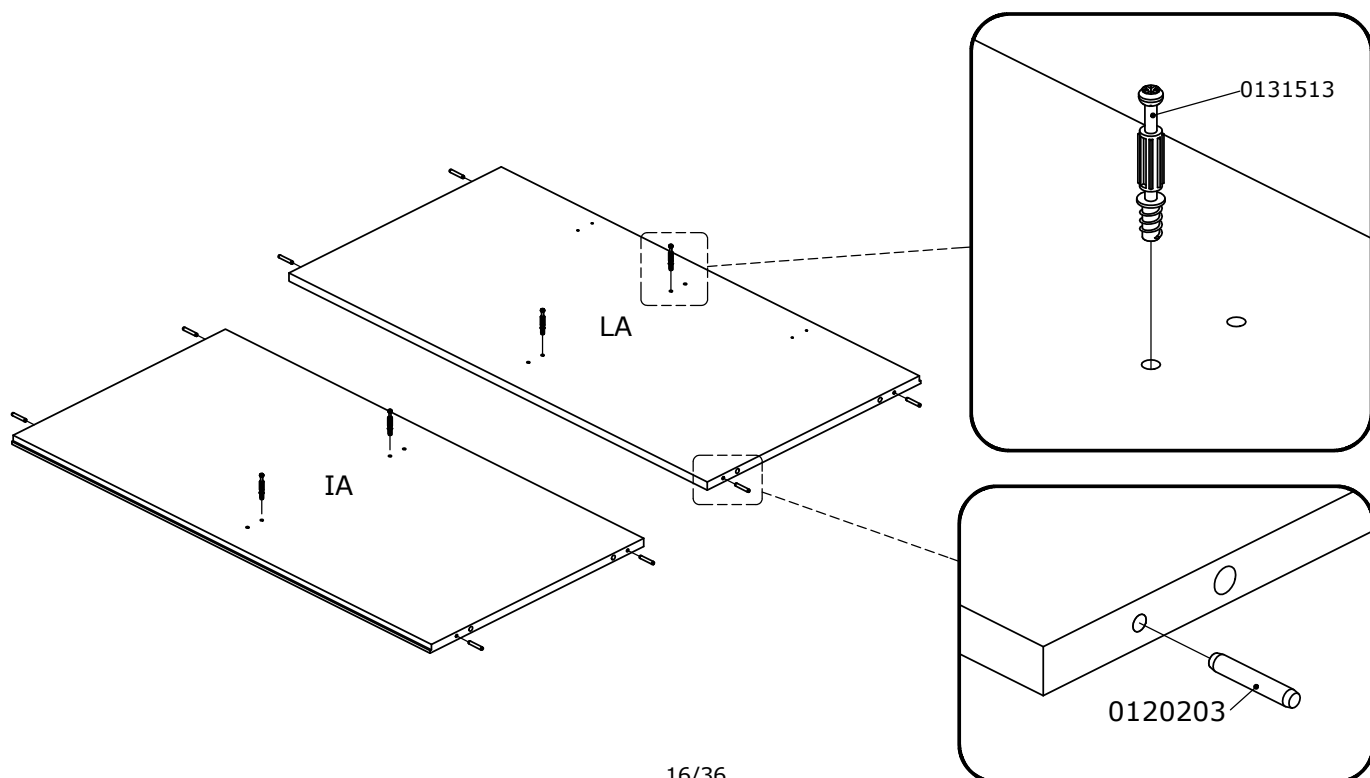

8

0113451 x 2  31x101x15x1,3 mm	0125440 x 4  Ø4x13 mm	
--	--	---

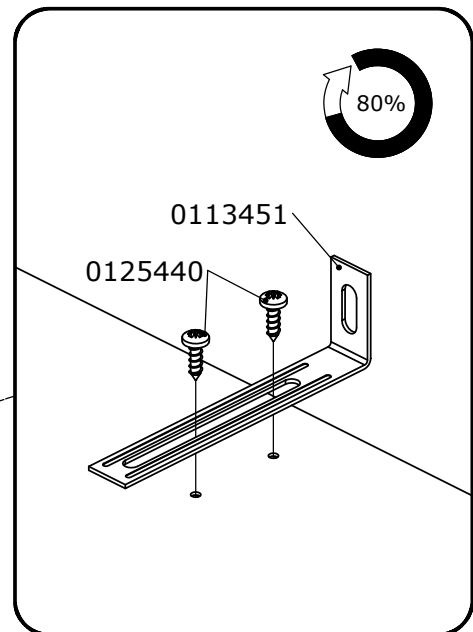
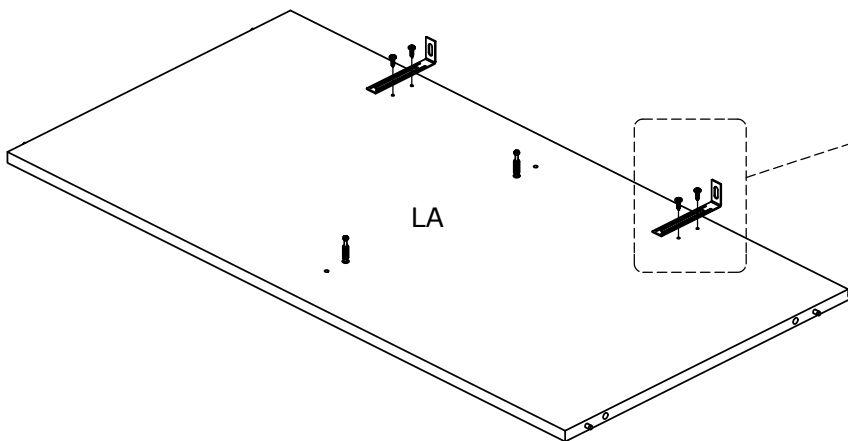

9

0131687 x 2  Ø15x9,5 mm	
--	---

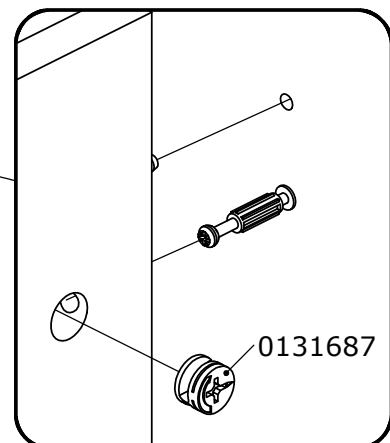
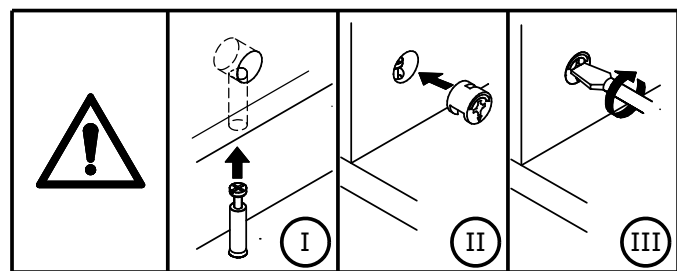
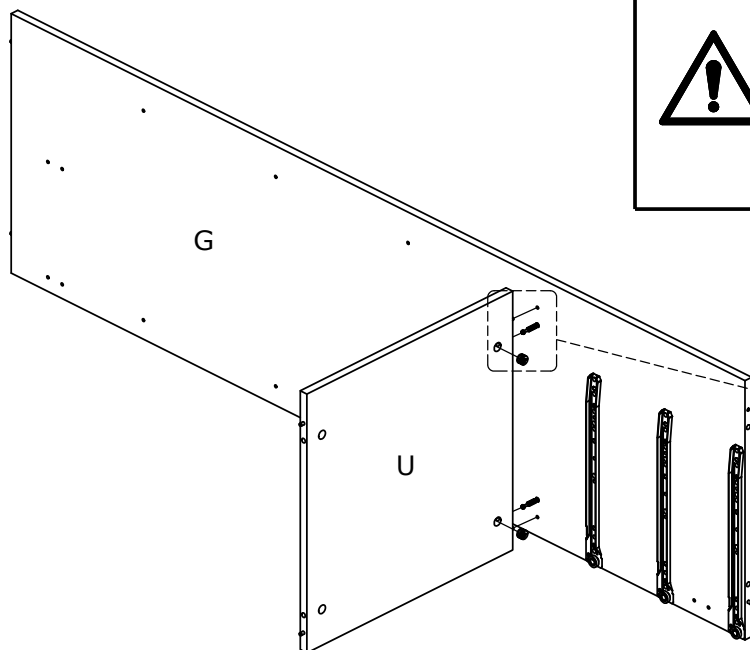

10

0131687 x 4

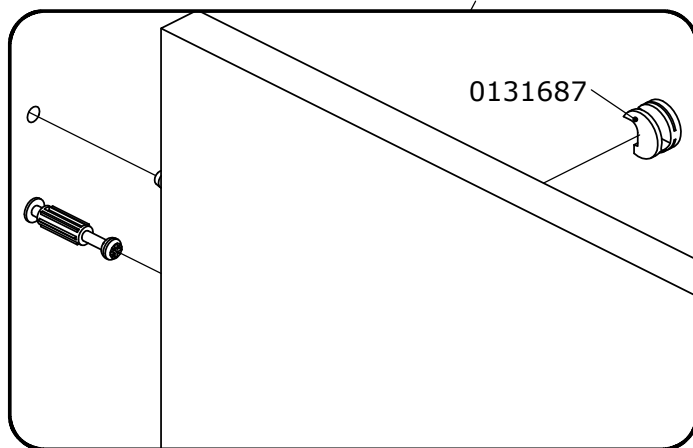
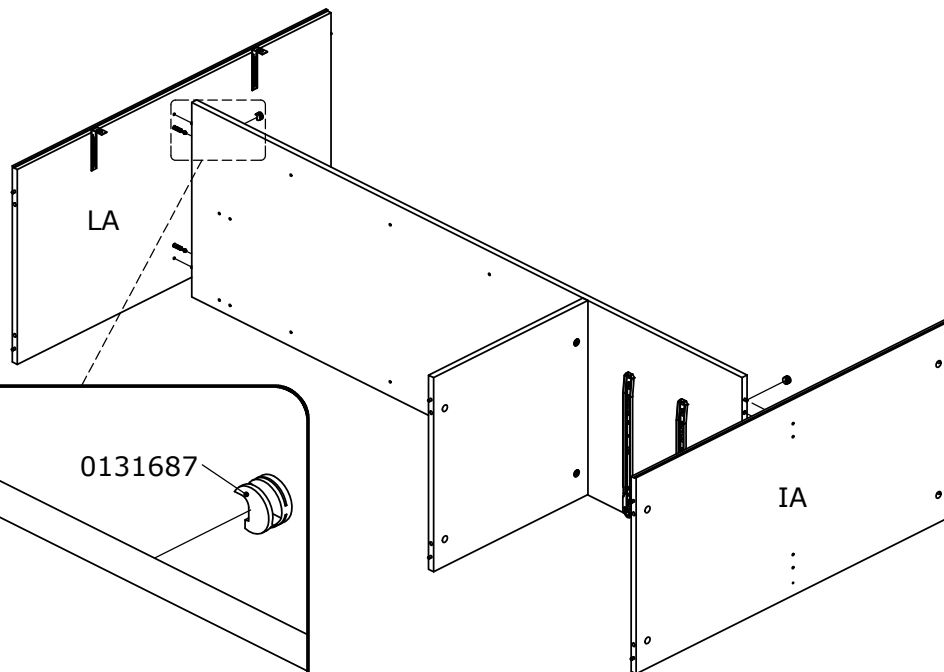
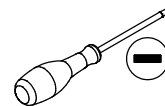



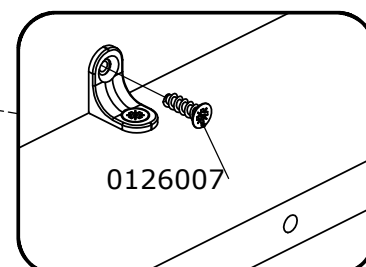
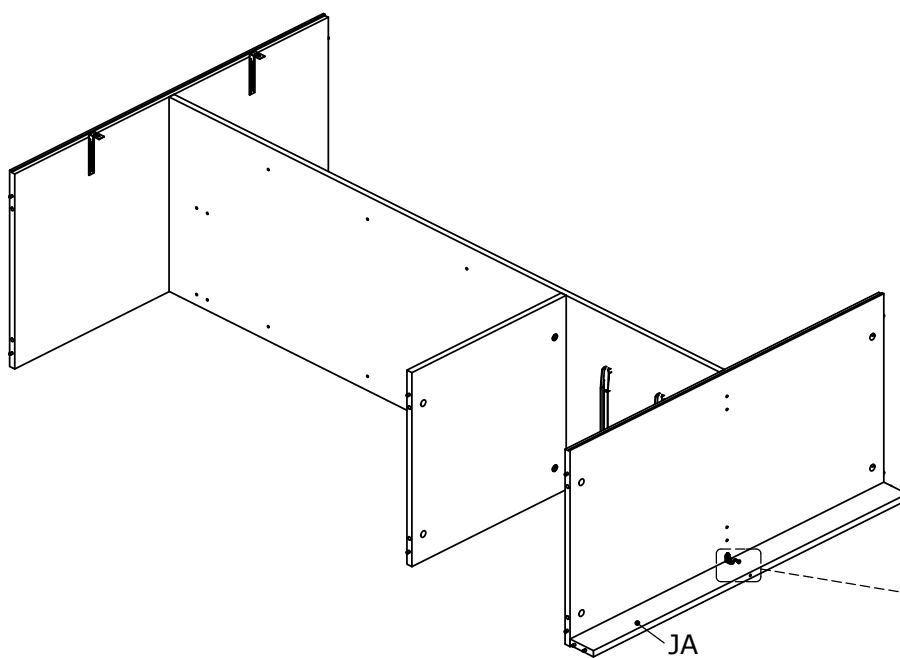
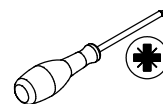

11

0126007 x 1

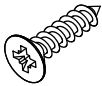

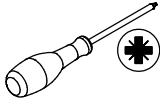
12

0125233 x 3  Ø3,5x15 mm	0126040 x 6  Ø6,3x10,5 mm	0141655 x 3  L=350 mm	
--	--	--	---

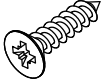
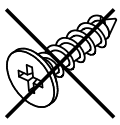

0125233  Ø3,5x15 mm	<del>0125215  Ø3x12 mm</del>
--	--

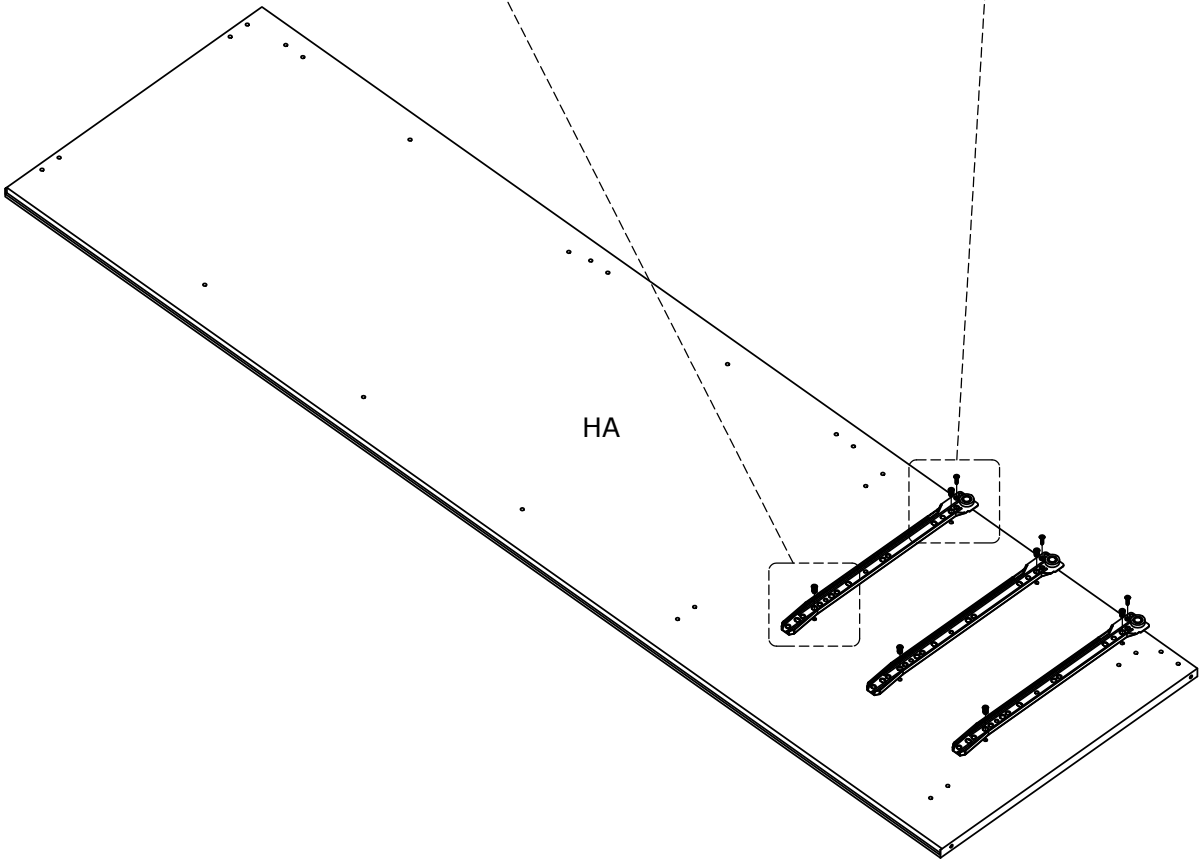
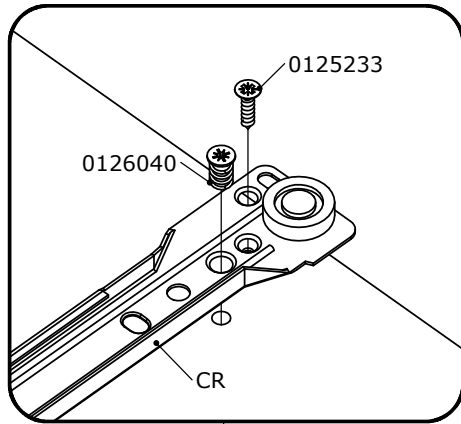
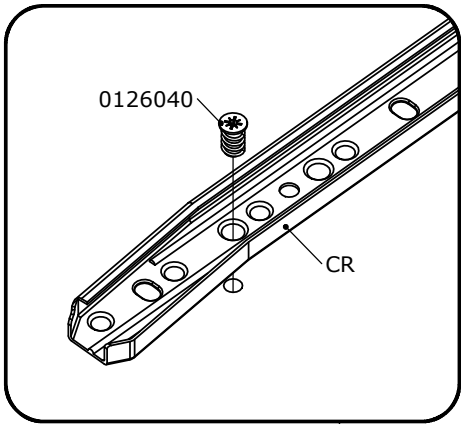
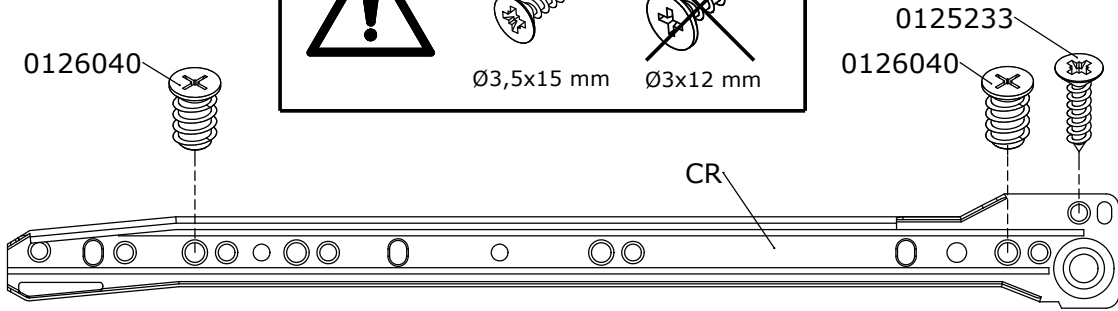

13

0131513 x 6  
Ø7,5x44 mm

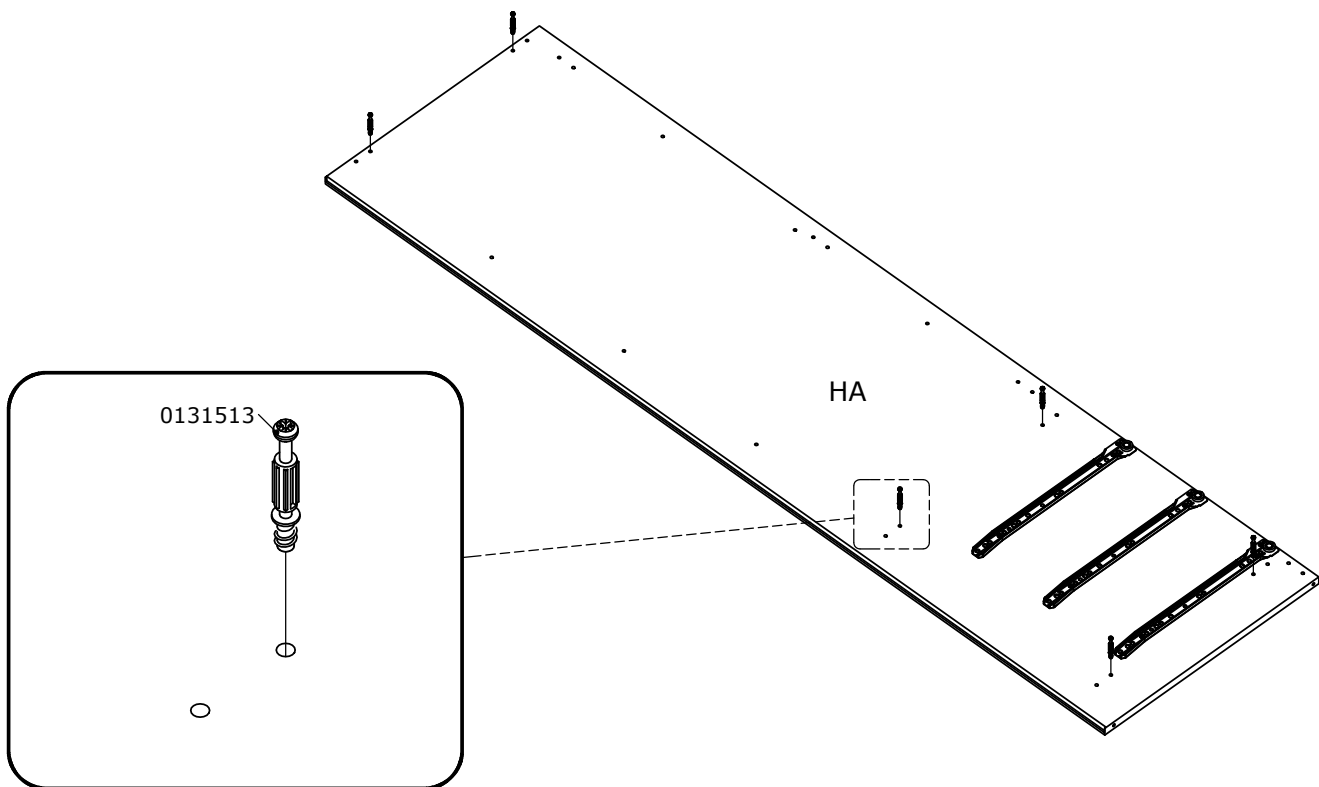
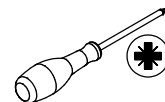

14

0131513 x 4  
Ø7,5x44 mm

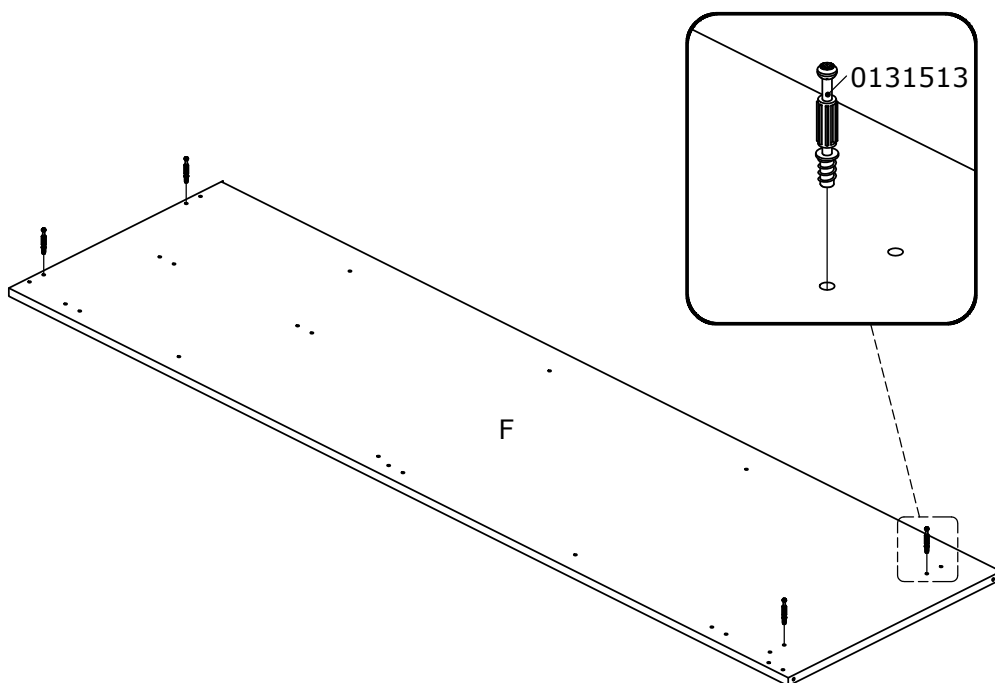
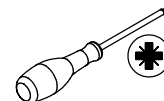

15

0110621 x 1  18x45,5x12 mm	0126040 x 2  Ø6,3x10,5 mm	
---	--	---

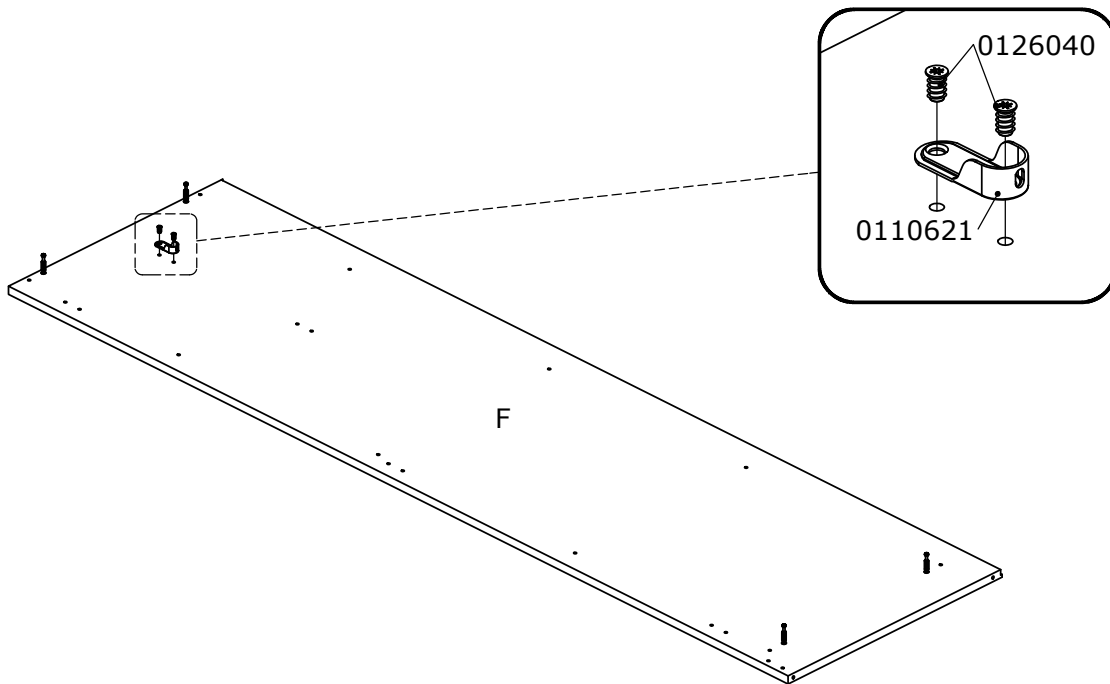

16

0131687 x 10  Ø15x9,5 mm	
---	---

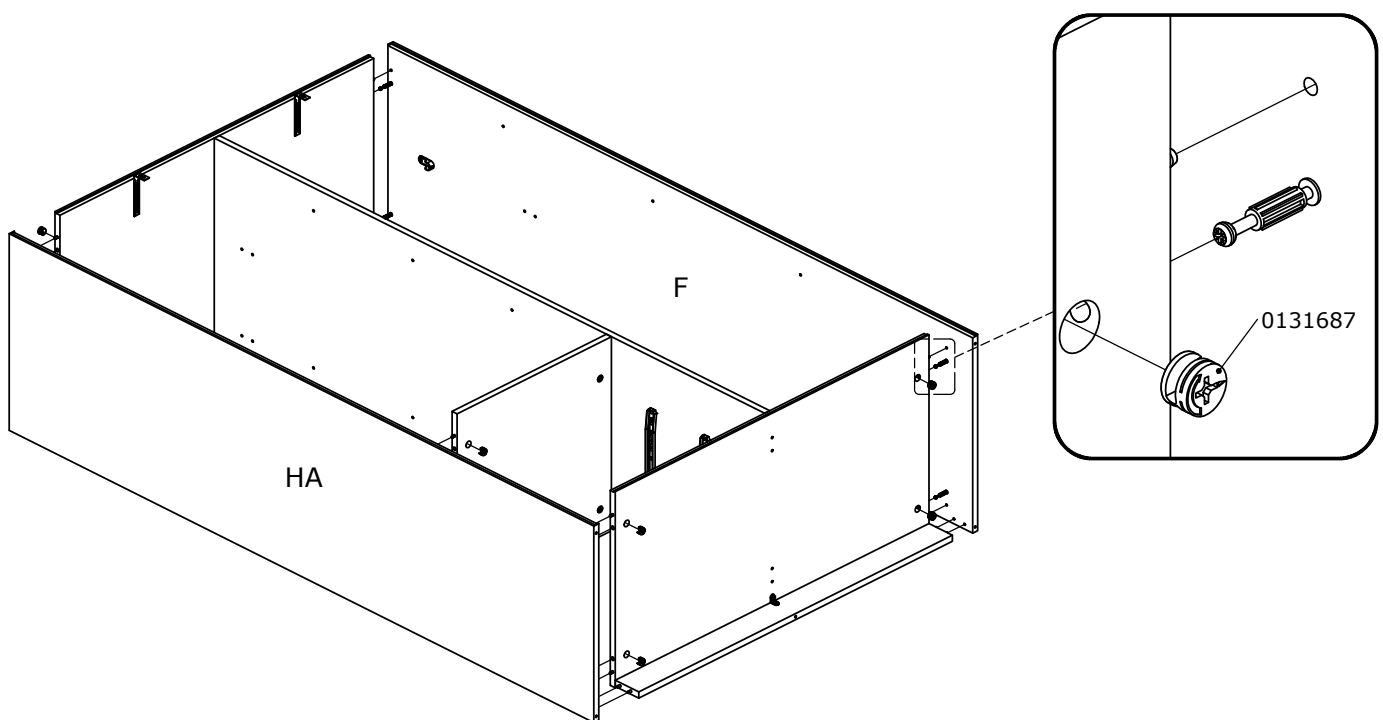

17

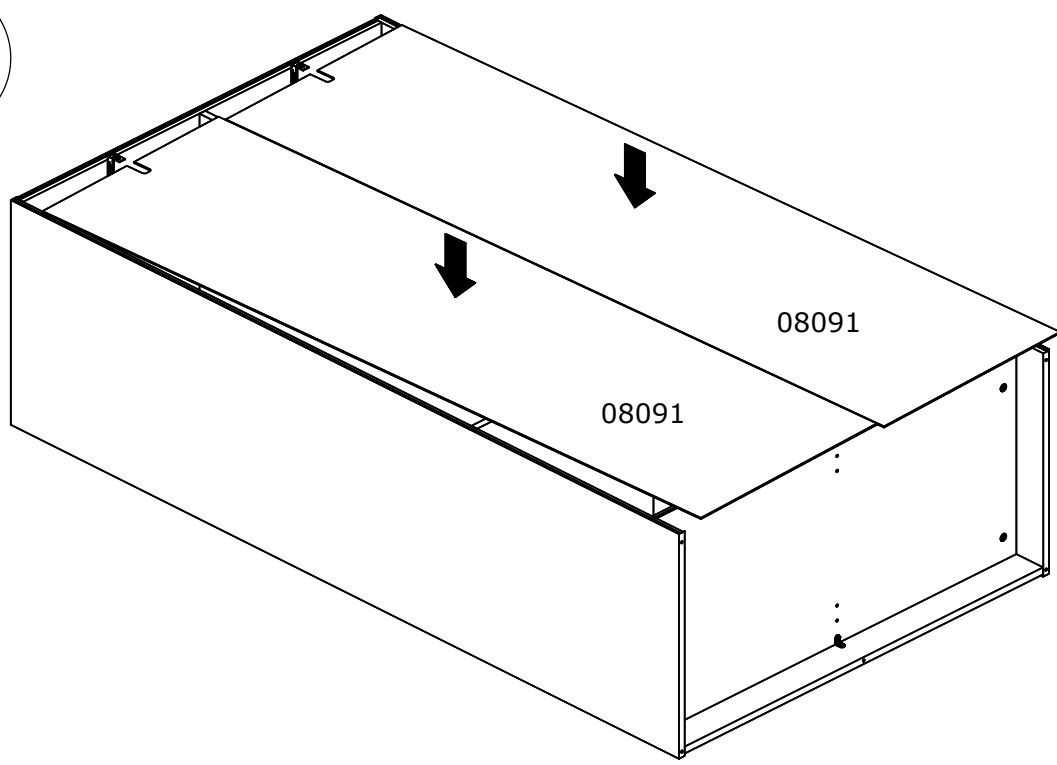

18

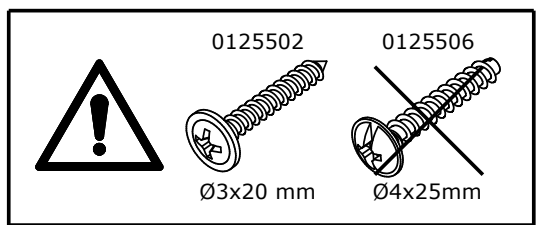
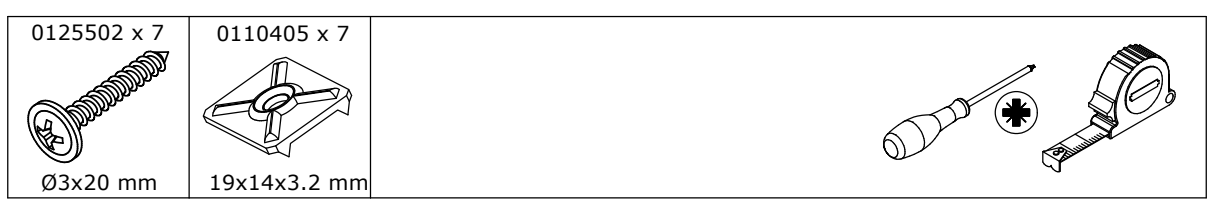

  $XX=YY \ 90^\circ$

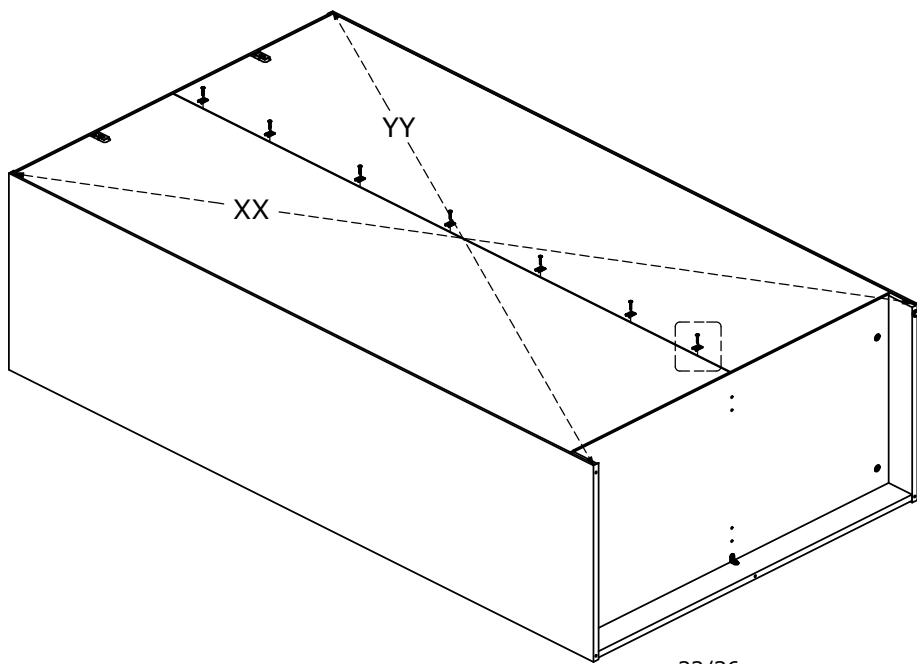
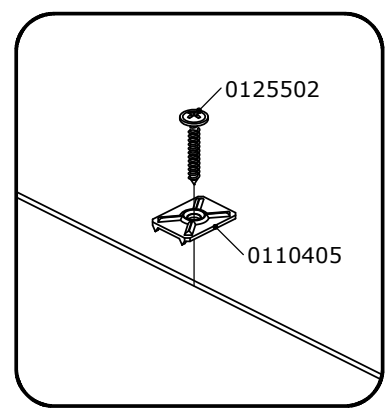

19

0123006 x 46  1,4x25 mm	0198202 x 1  45x20x16 mm	
--	---	---

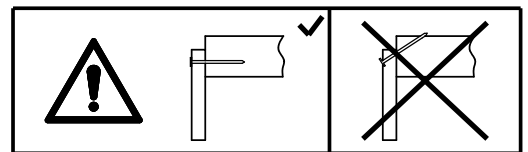
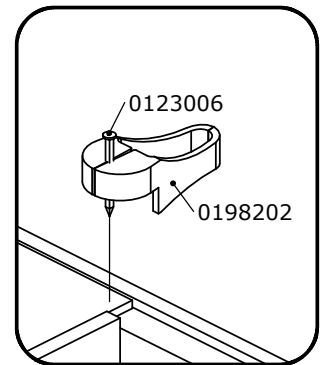
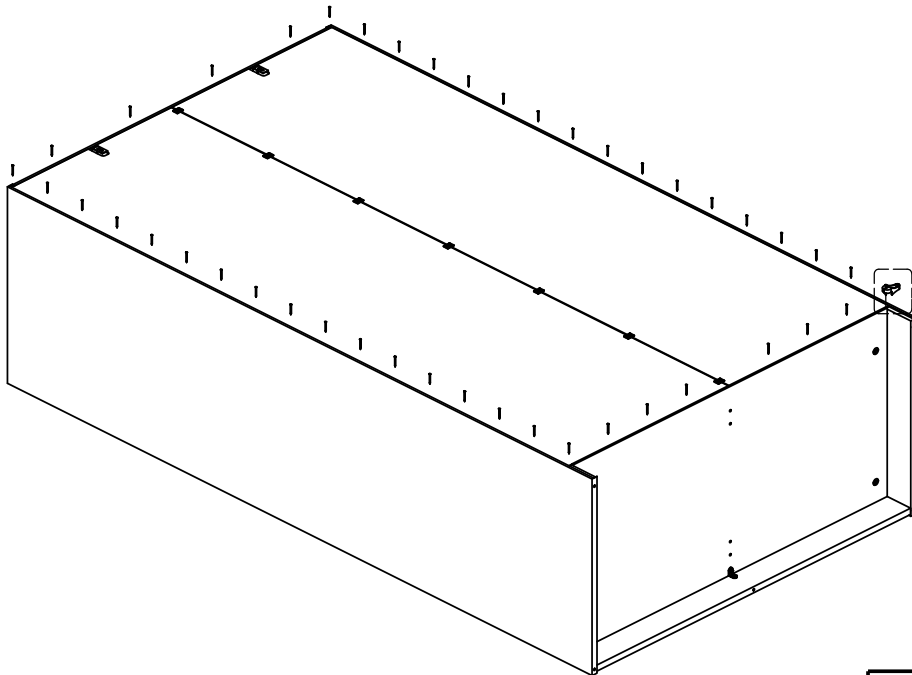

20

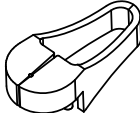
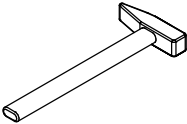
0163015 x 5  Ø15x4,8 mm	0198203 x 1  45x20x16 mm	
--	---	---

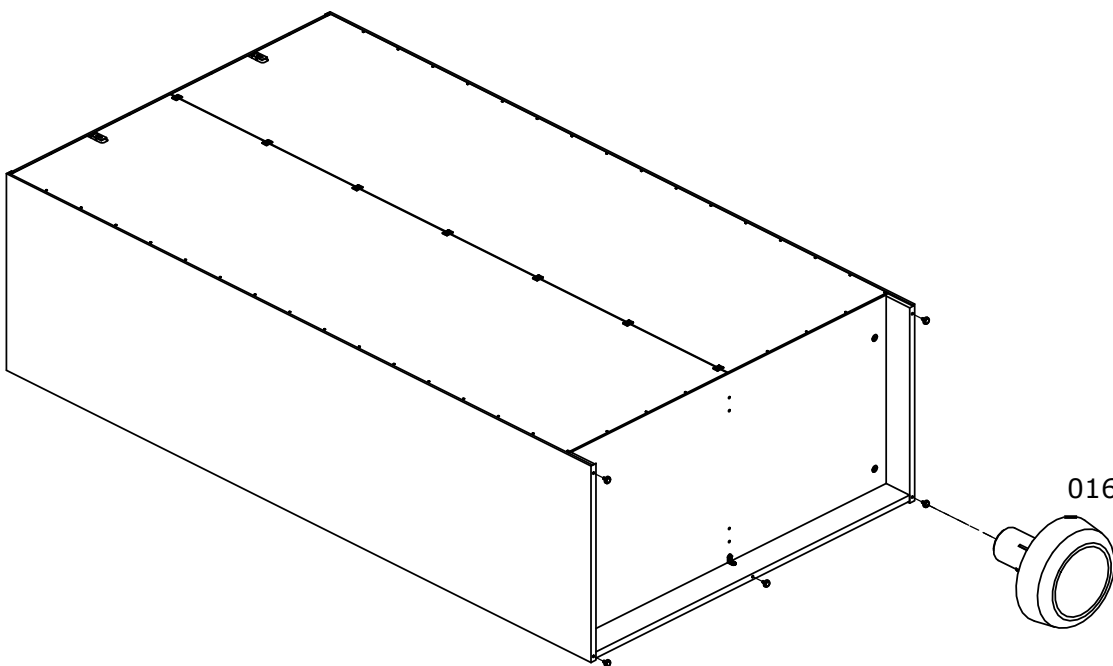

21

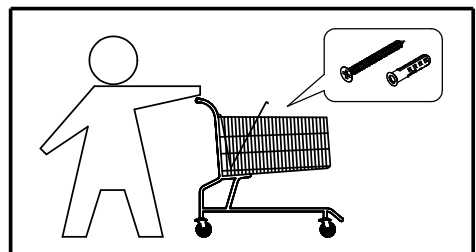
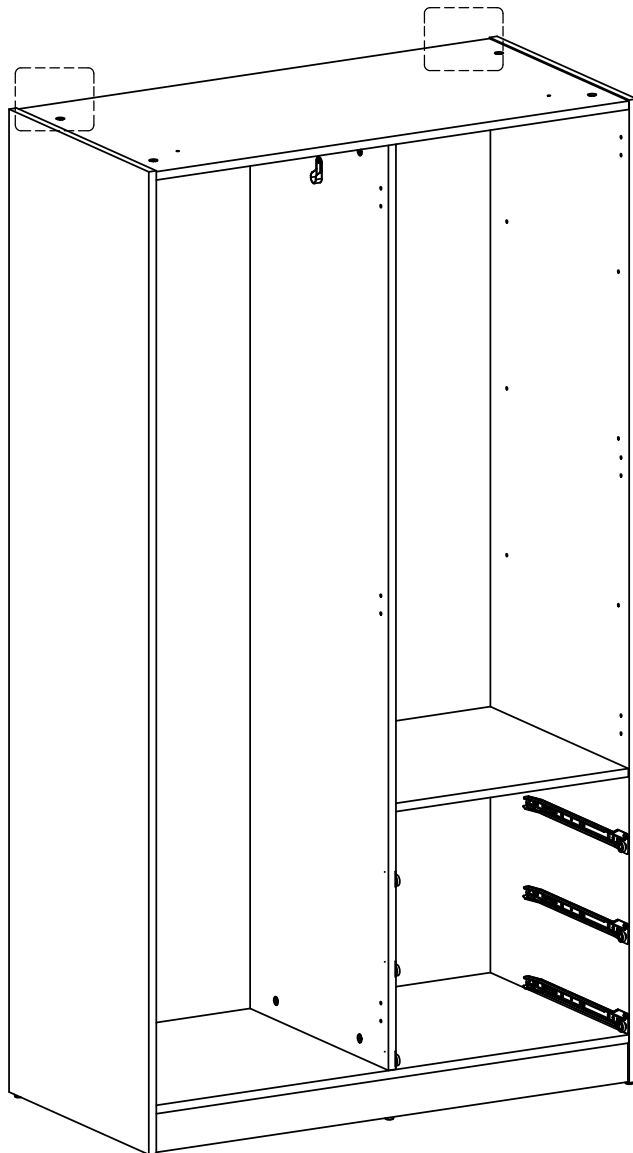
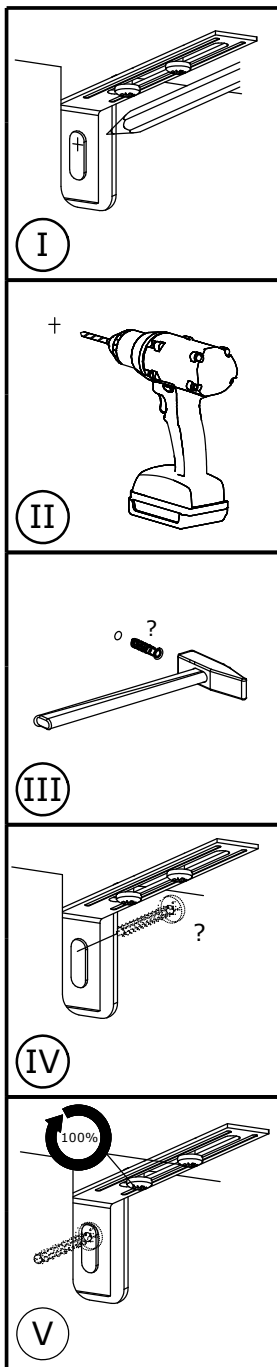
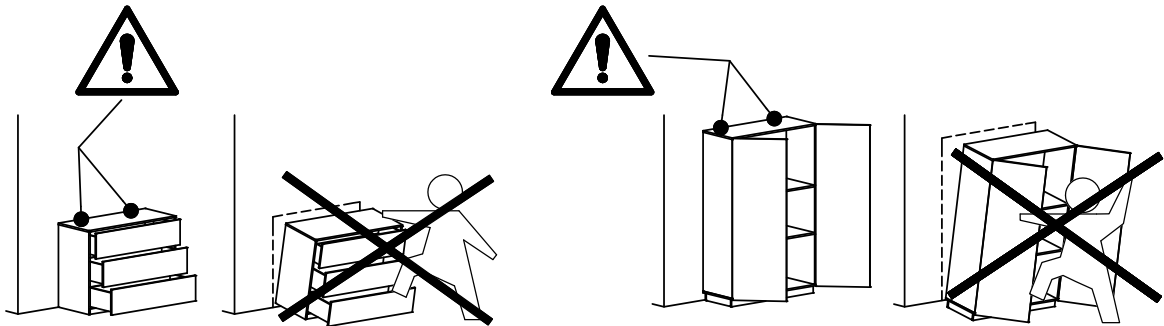
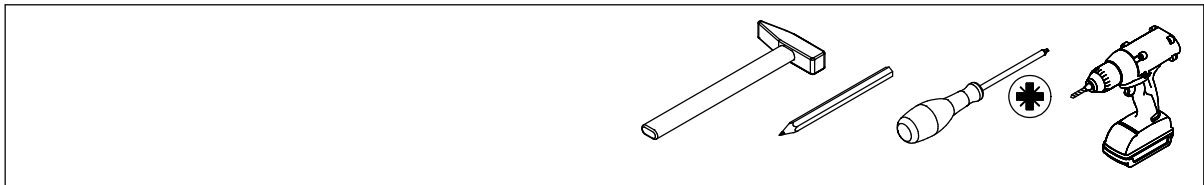

22

0111042 x 12  
21x19,3x12 mm

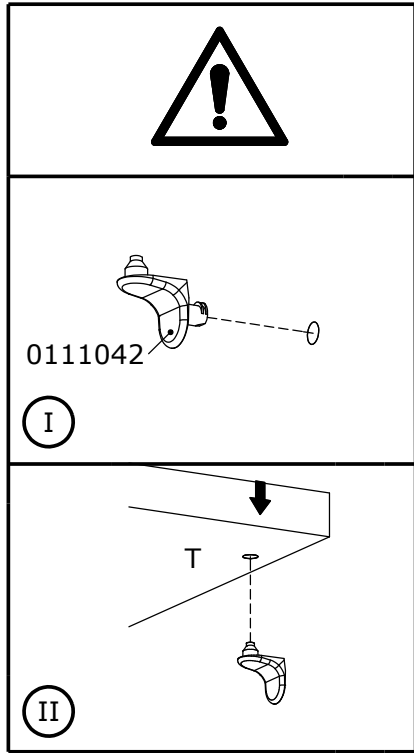
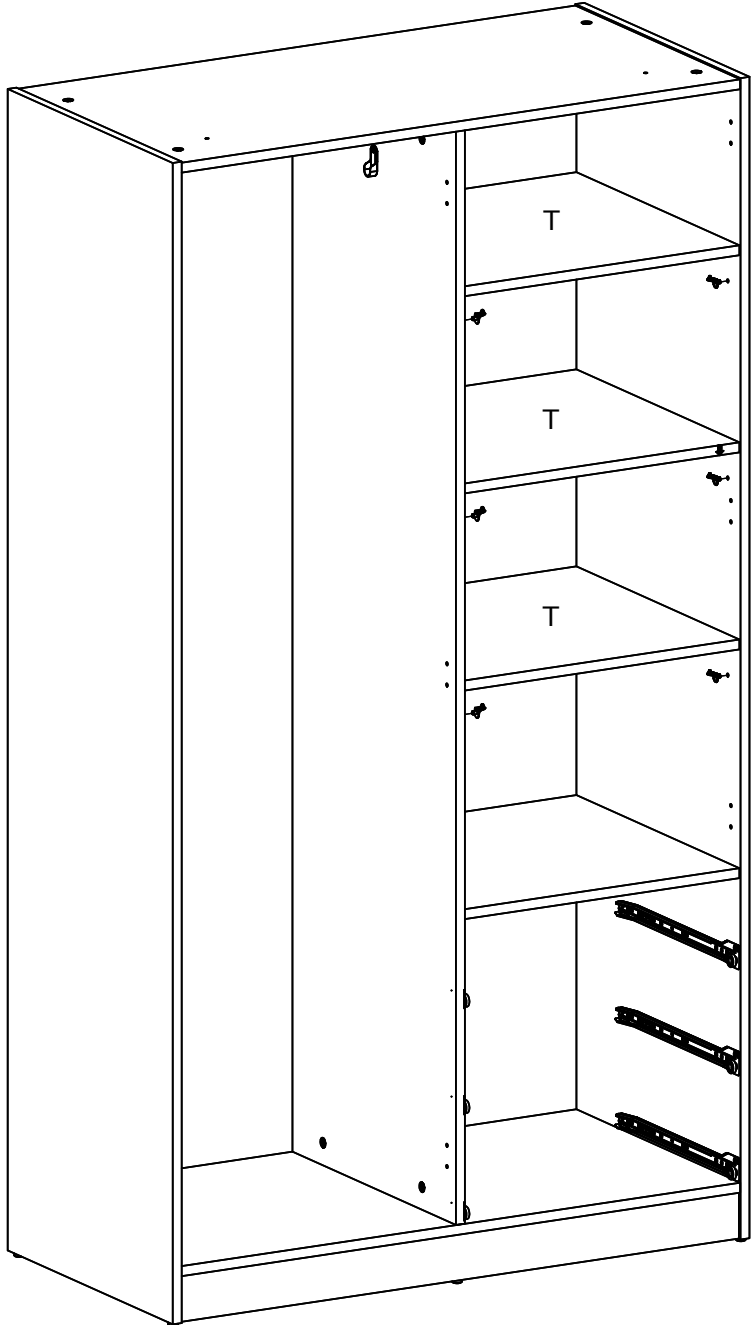
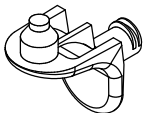

23

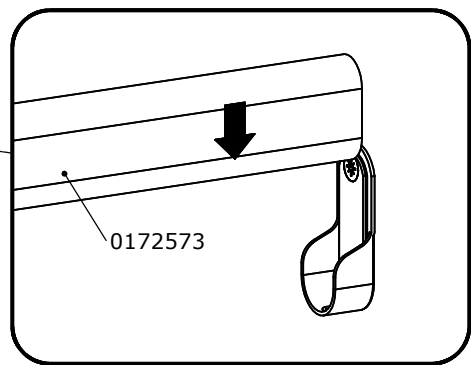
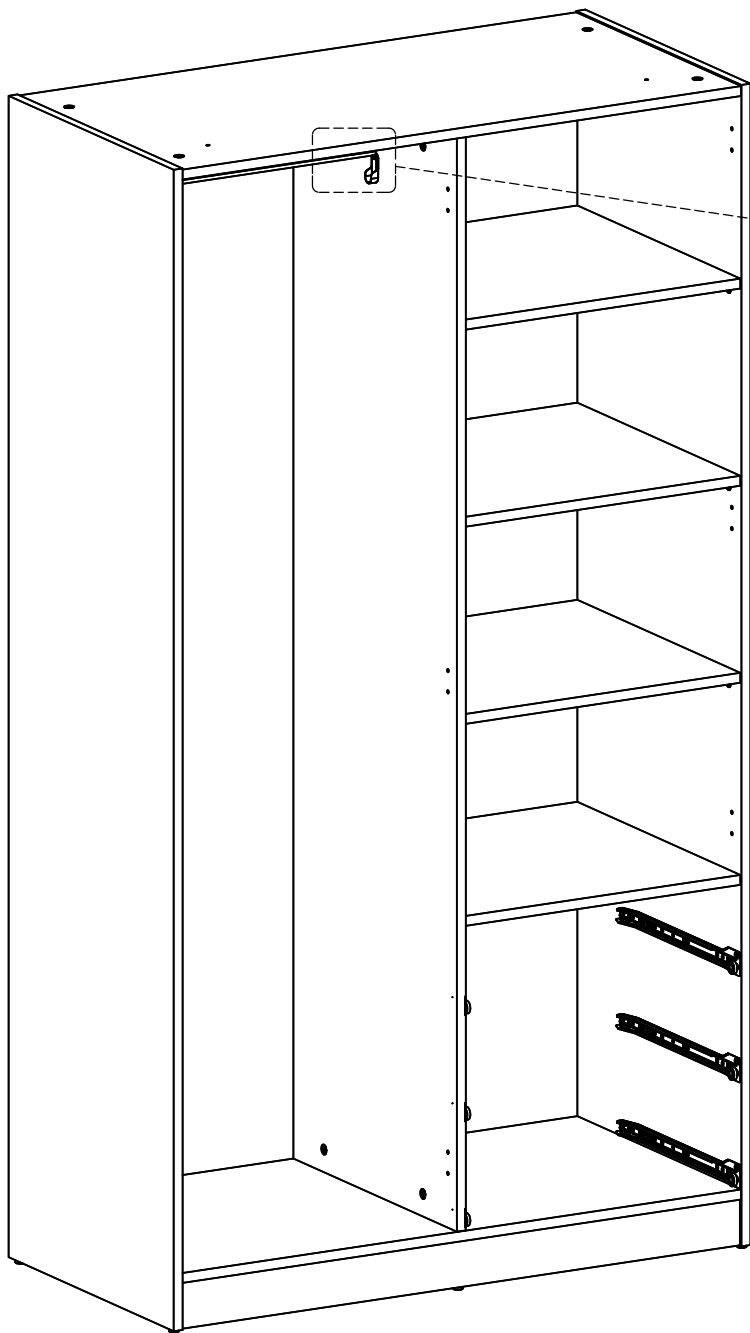

24

0152500 x 6



Ø26 mm, FK8

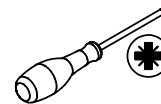

I

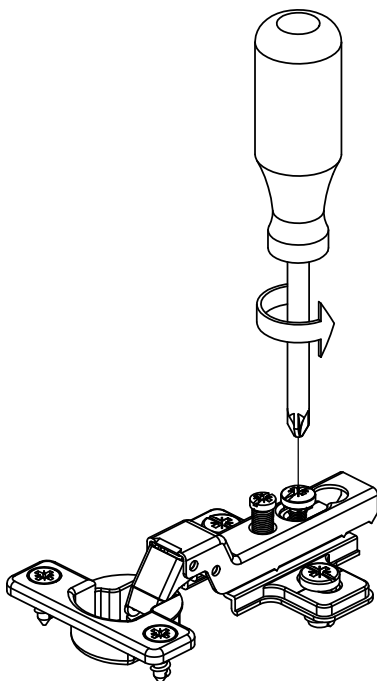

II

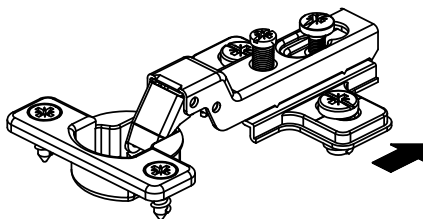

III

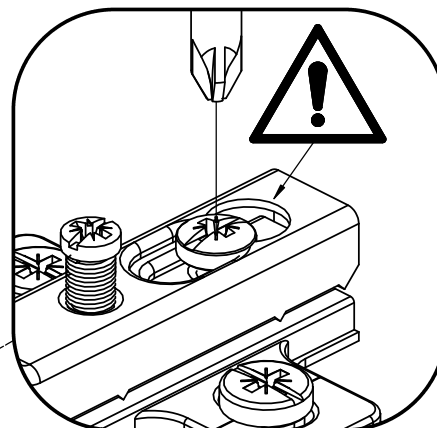
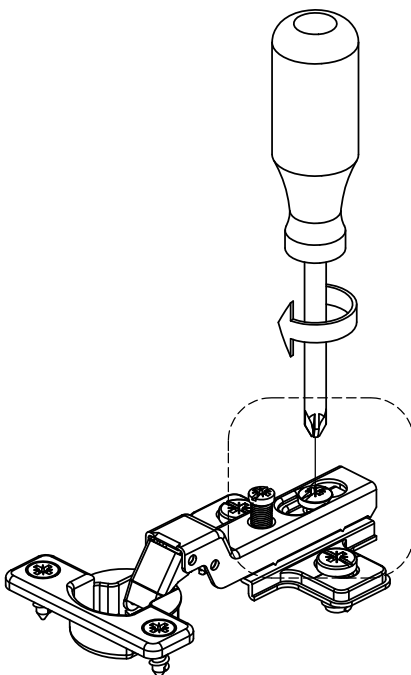

25

0152500 x 6



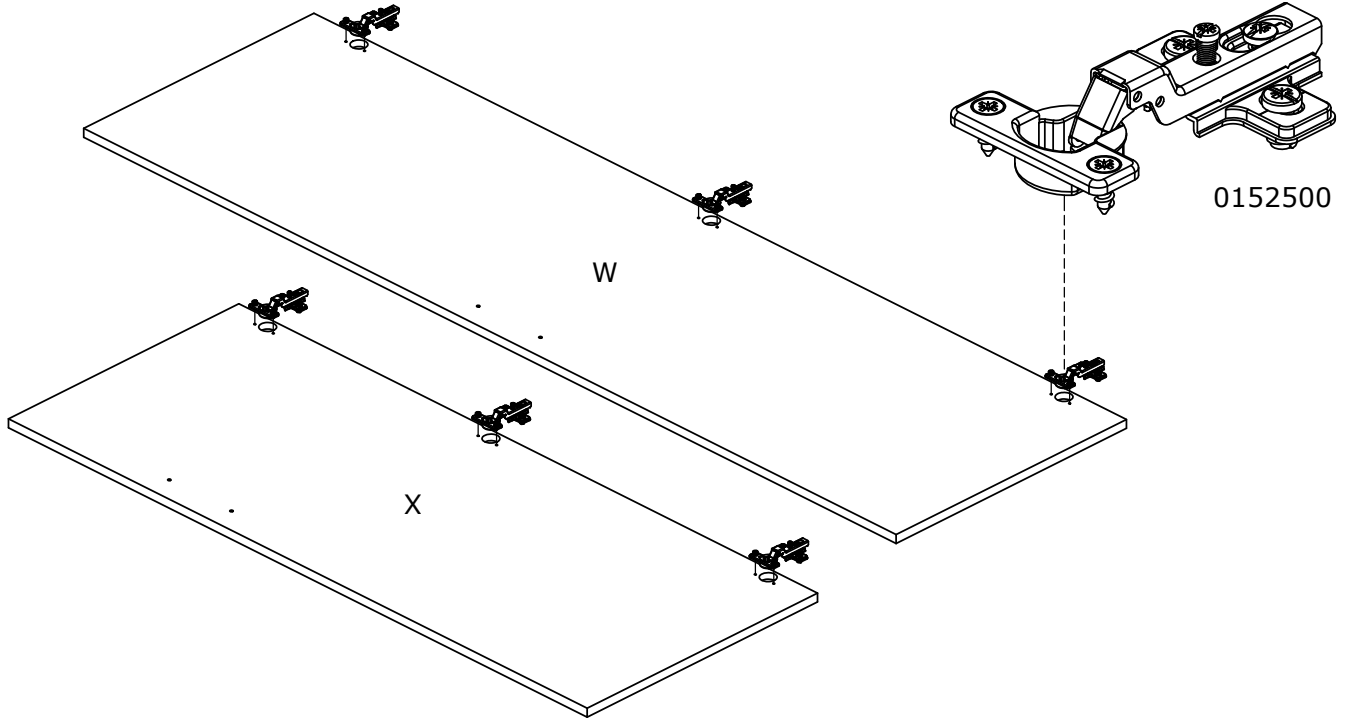
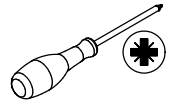

Ø26 mm, FK8

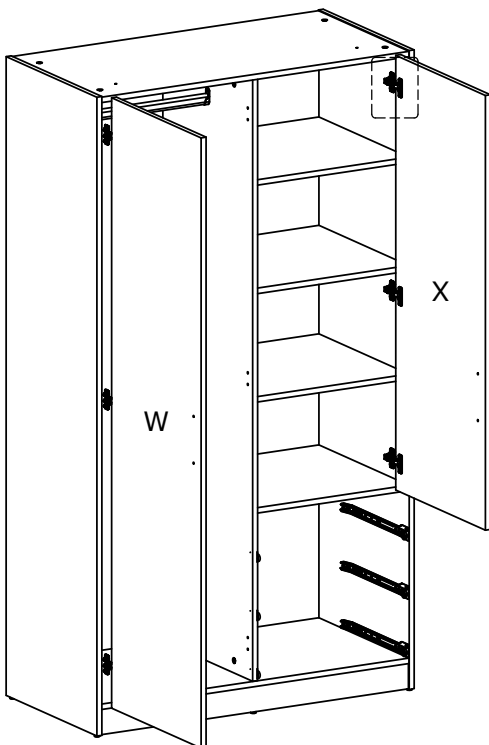
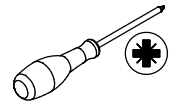

26

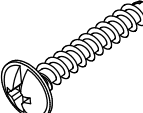
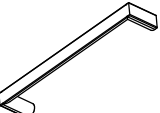

27

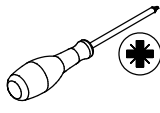
<p>0125506 x 4  Ø4x25mm</p>	<p>0180605 x 2  136x26x11mm</p>	<p>0196203 x 4  Ø7x1,5 mm</p>	
--	--	--	---

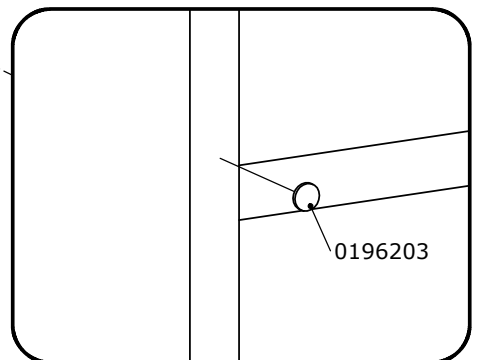
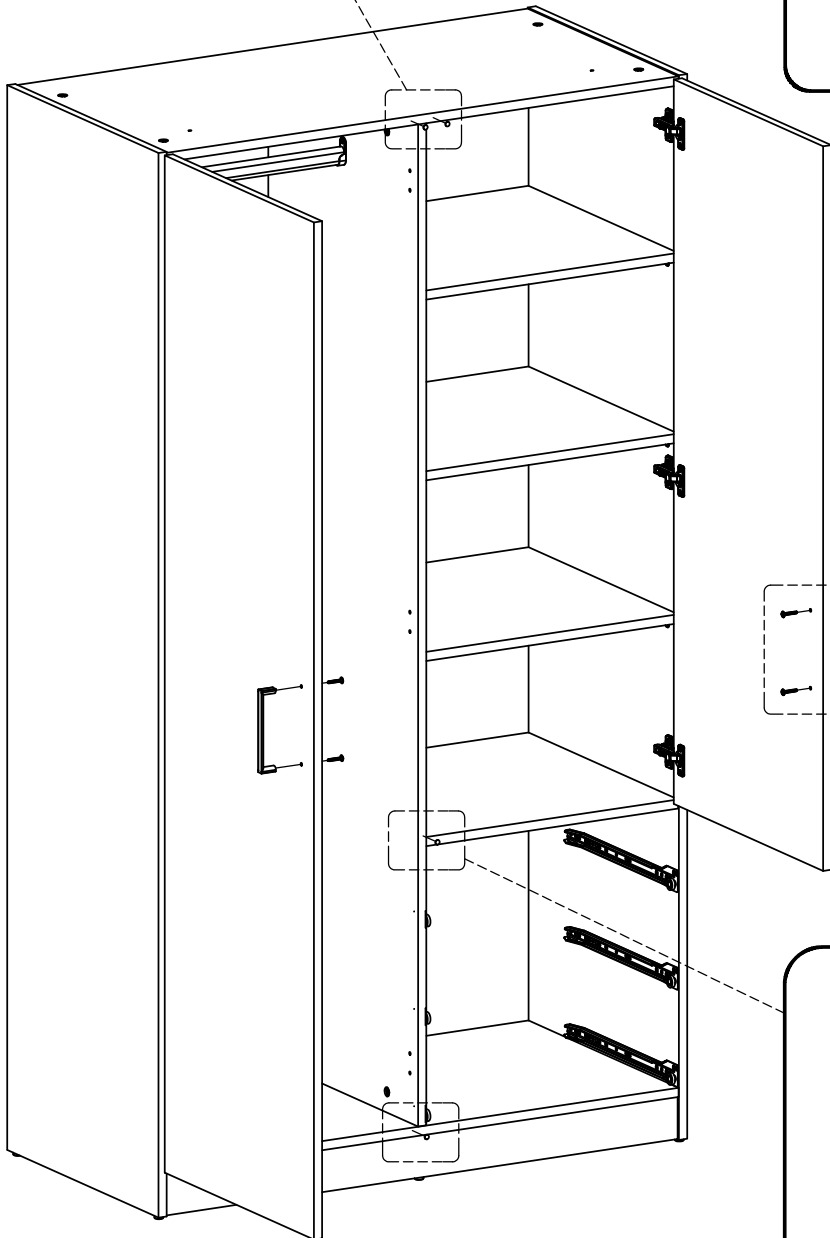
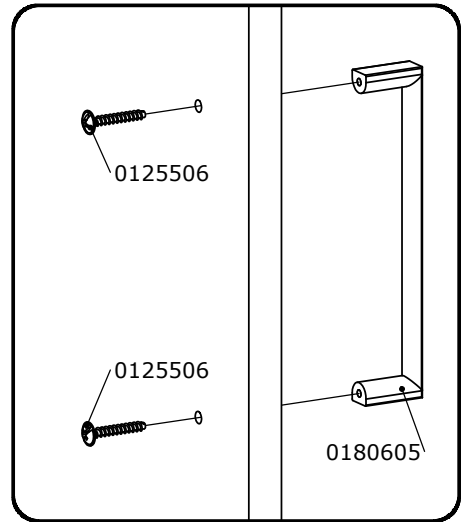
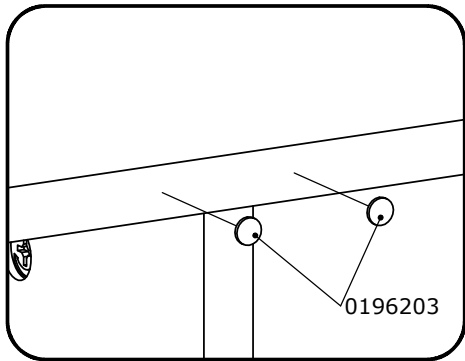

28

0131513 x 6

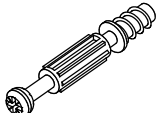

Ø7,5x44 mm

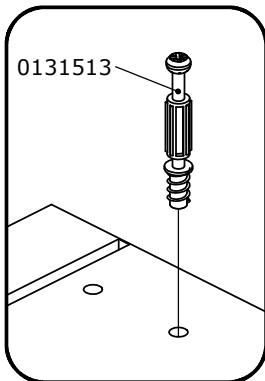
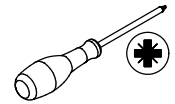

0131513



30

0131687 x 6

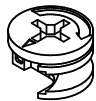

Ø15x9,5 mm

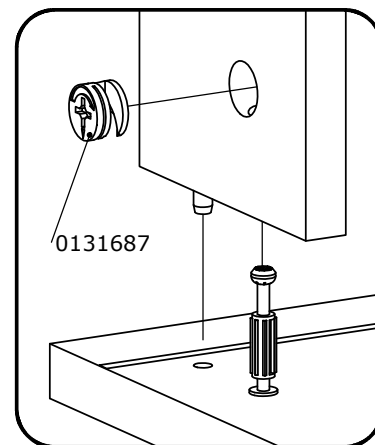
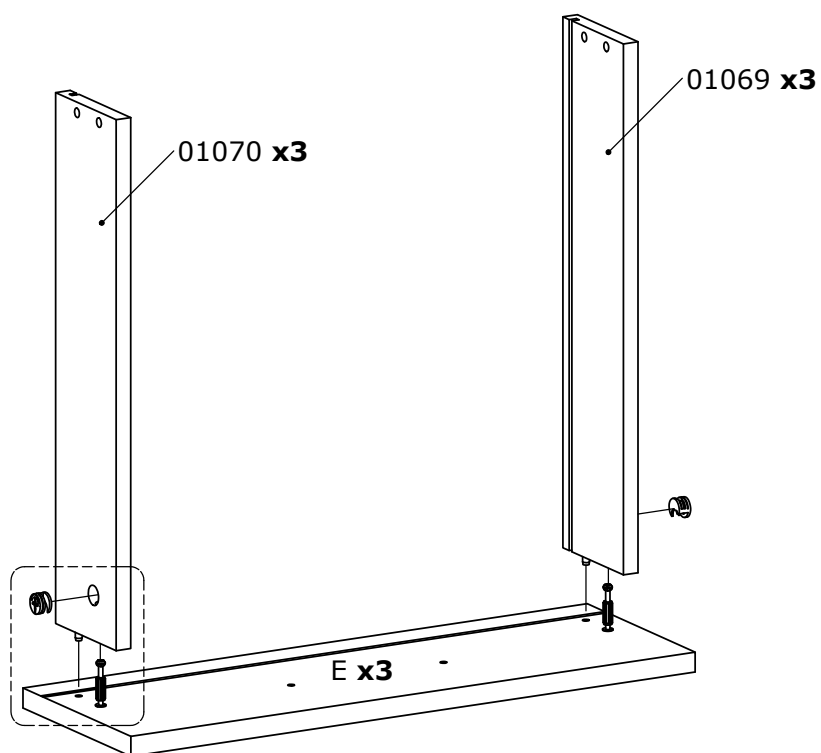
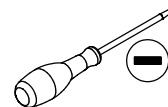

31

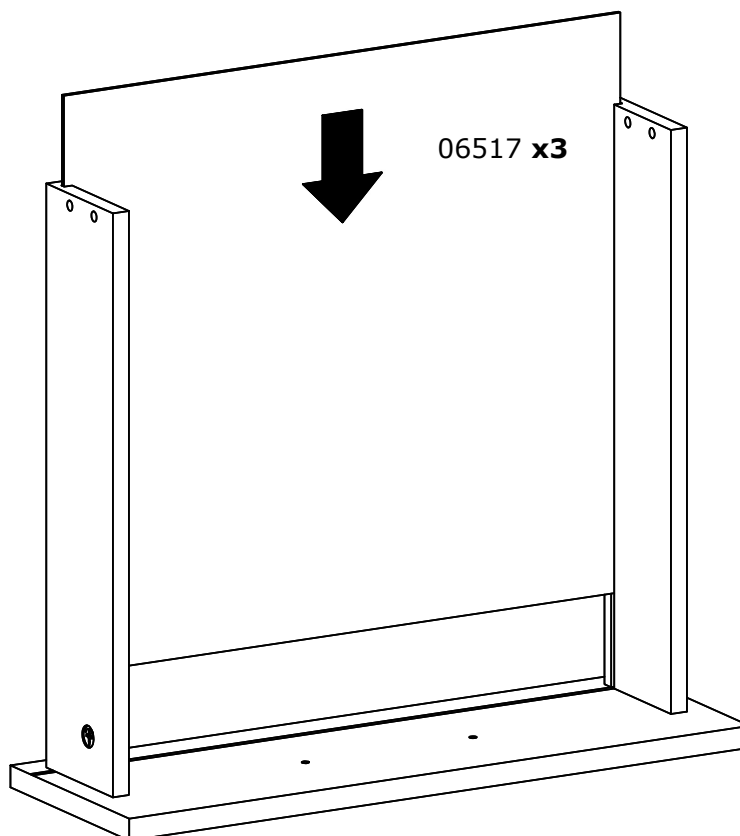

32

0120228 x 12  Ø6,3x40 mm	
---	---

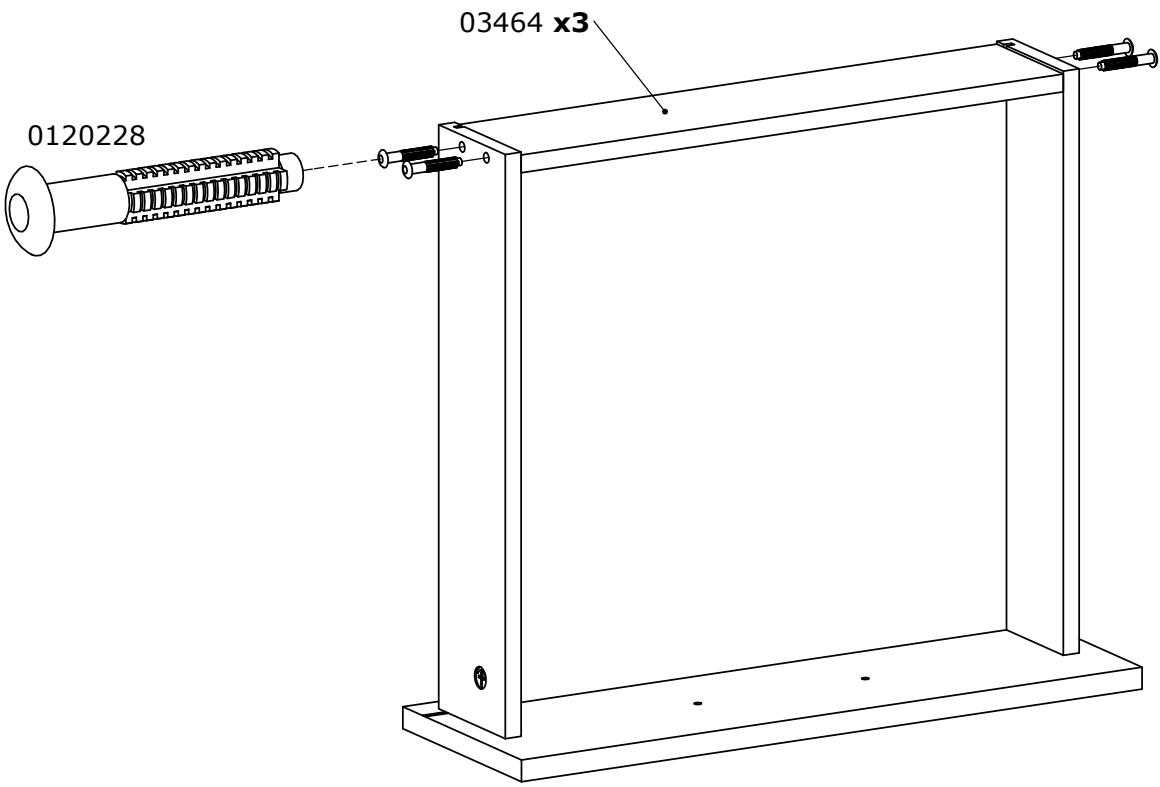

33

0125215 x 12  Ø3x12 mm	0141655 x 3  L=350 mm	
---	--	---

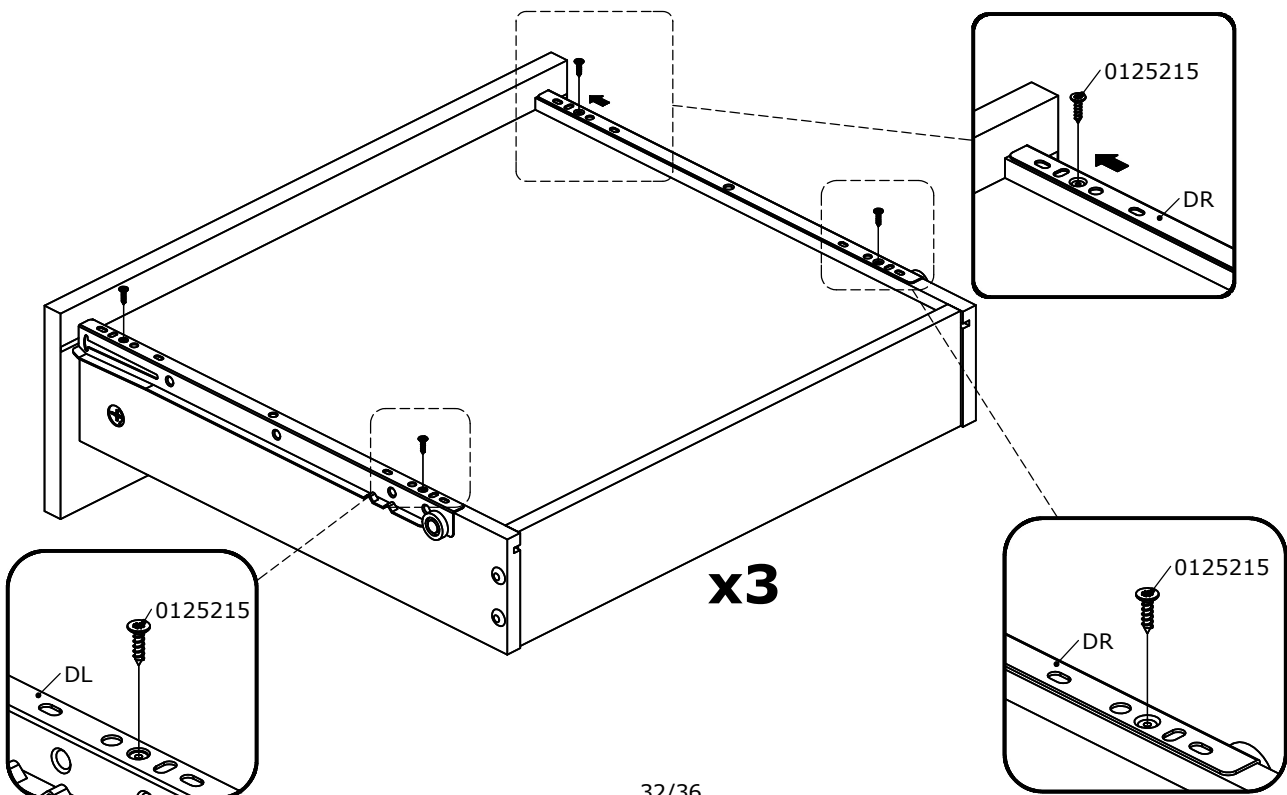

34

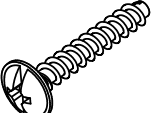
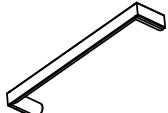
0125506 x 6  Ø4x25mm	0180605 x 3  136x26x11mm
---	---

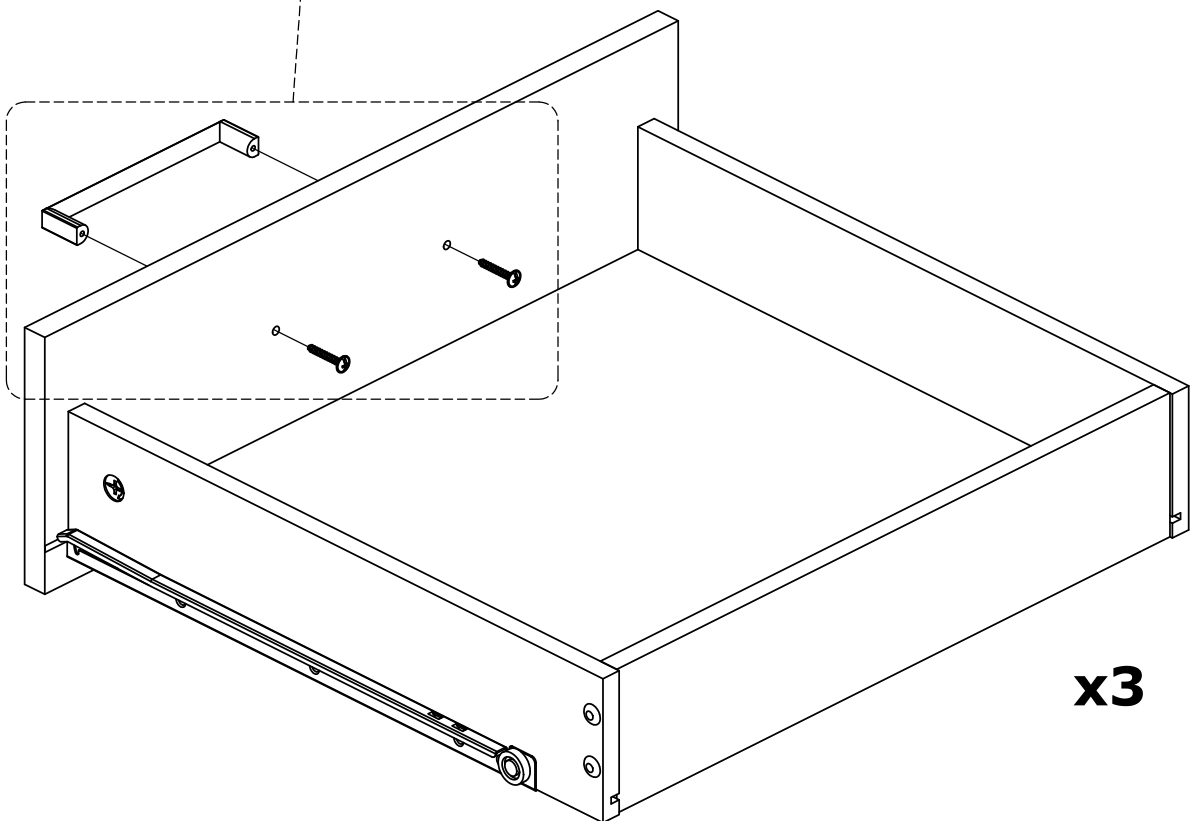
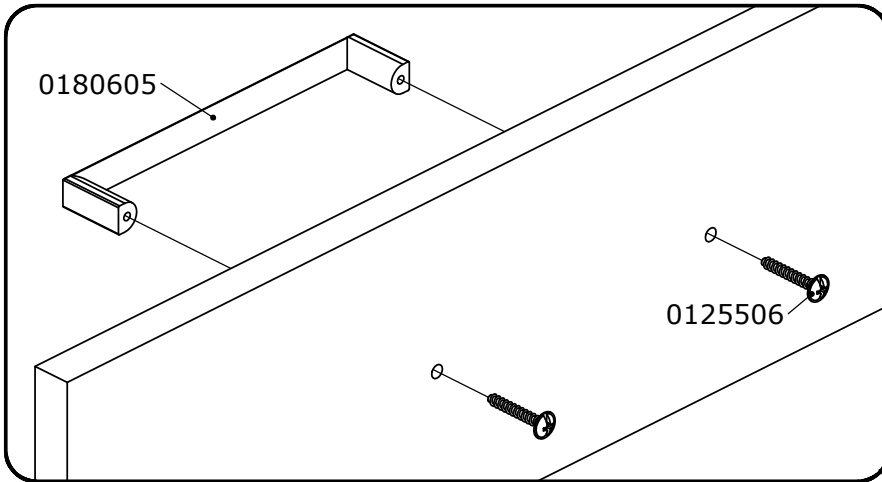
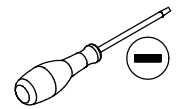

x3

35

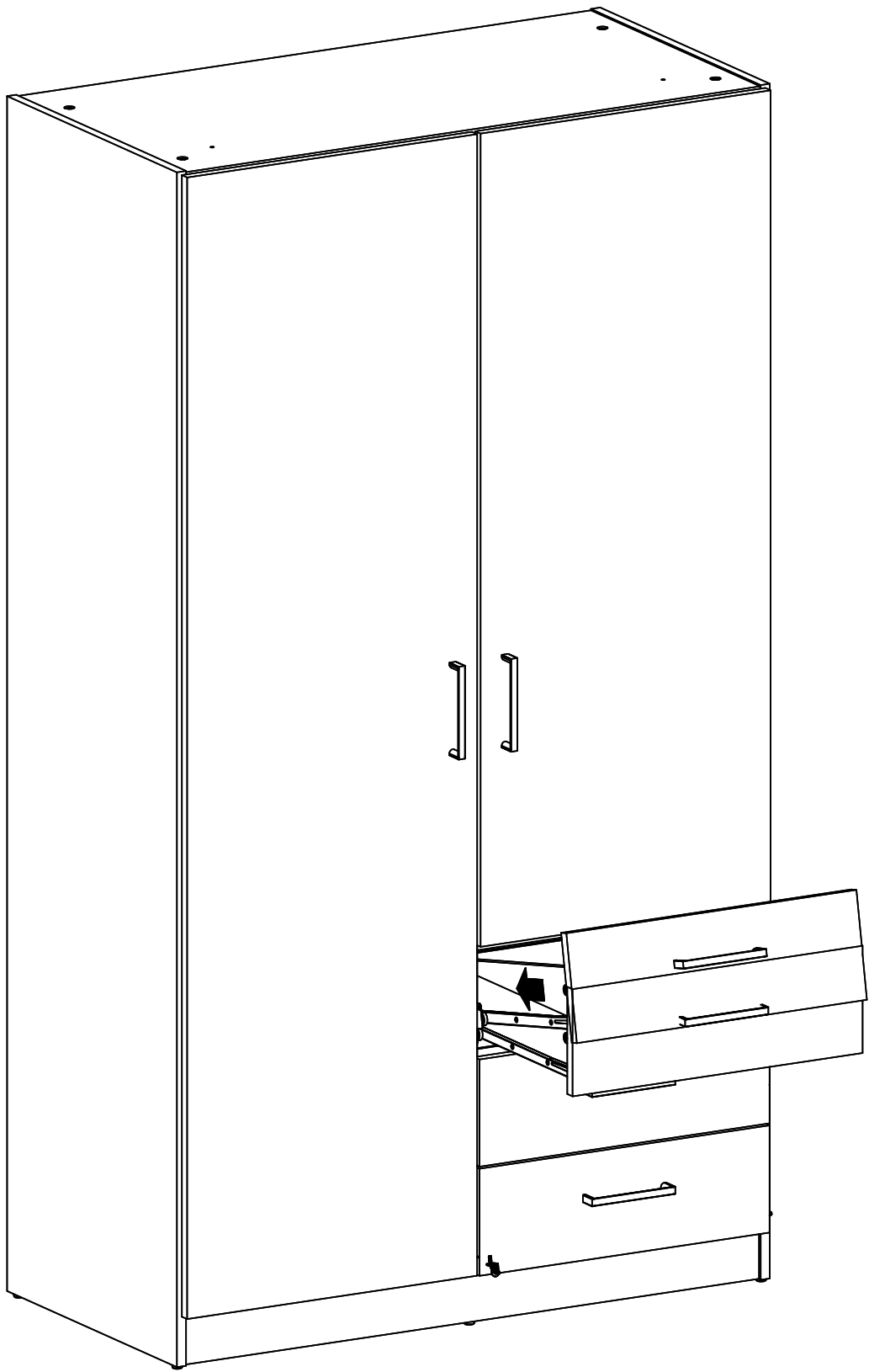

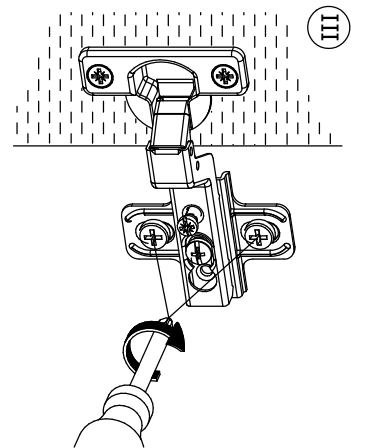
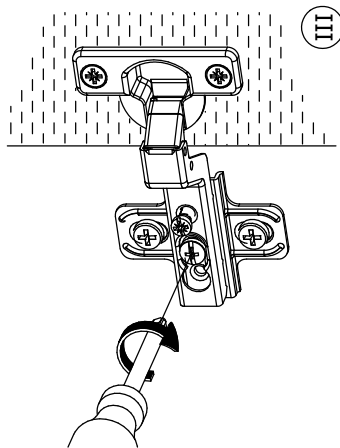
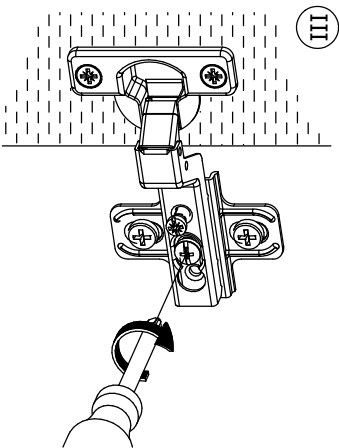
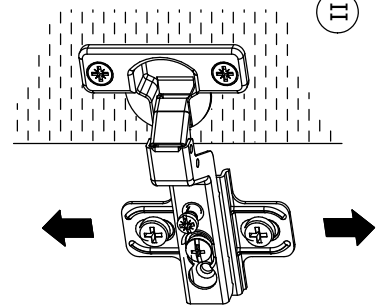
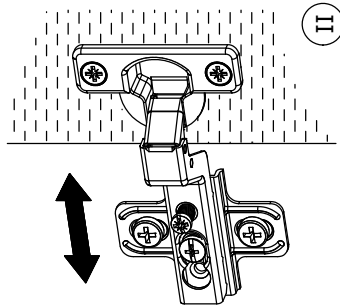
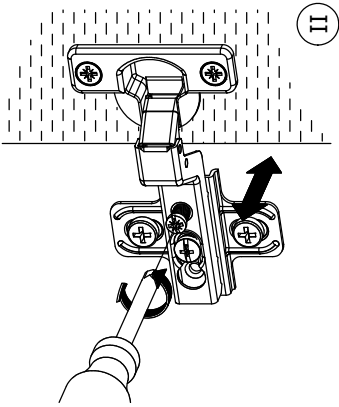
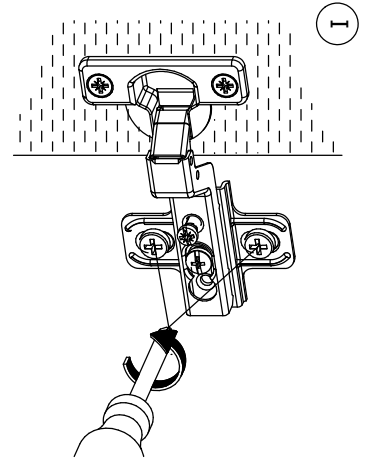
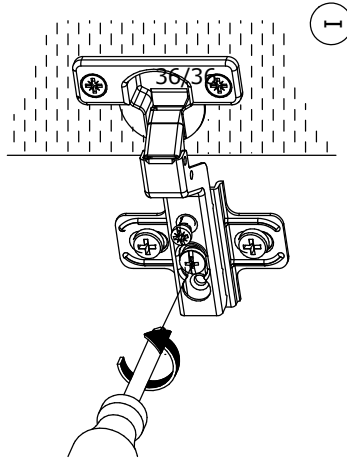
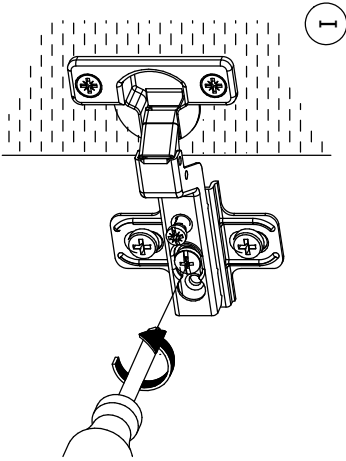
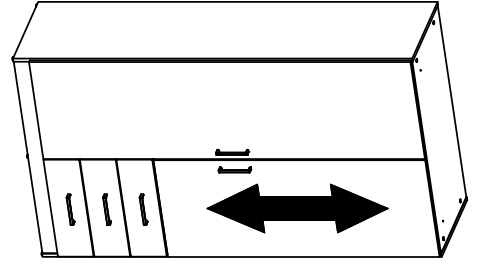
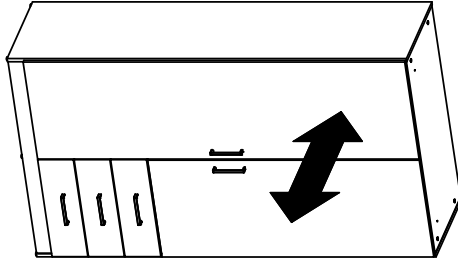
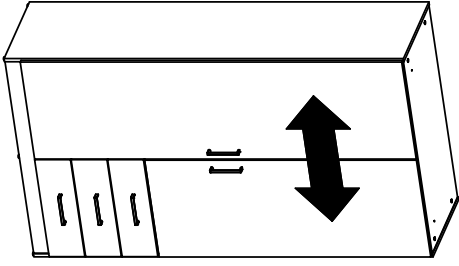

# 37

